

OMCN
S.p.A.

ready

PROMO | 2024

ESTESA FINO AL 31.05.2024
Prezzi netti I.V.A. esclusa

FERRAMENTA
UTENSILERIA
ARTICOLI TECNICI

MADE IN ITALY

24 MESI
Garanzia



3020 - Portata 3000 kg

€ 1.078,00 - € 639,00



TOP LINE

- Design completamente innovativo.
- Punti presa super ribassati.
- Manico ergonomico.
- Supporto piattello a base ampia.
- Dotati di pedale di avvicinamento.
- Dotati di comando di discesa manuale.
- Piattello in gomma (Art. 3020).
- Piattello in acciaio (Art. 3030).
- Ruote in nylon.

3030 - Portata 6000 kg

€ 1.617,00 - € 959,00



3000 - Portata 2000 kg

€ 782,00 - € 459,00



- Design completamente innovativo.
- Punti presa super ribassati.
- Manico ergonomico.
- Supporto piattello a base ampia.
- Piattello in gomma.
- Ruote in nylon.

3010 - Portata 2000 kg

€ 1.477,00 - € 875,00

Dotato di ruote in poliuretano con doppi rulli basculanti anteriori.



| ART. | | A mm | B mm | C mm | D mm | E mm | F mm | G mm | H mm | KG |
|------|---------|------|------|------|------|------|------|------|------|----|
| 3000 | 2000 kg | 480 | 95 | 350 | 290 | 130 | 200 | 660 | 810 | 39 |
| 3010 | 2000 kg | 710 | 95 | 480 | 485 | 130 | 210 | 1000 | 780 | 67 |
| 3020 | 3000 kg | 505 | 90 | 290 | 275 | 130 | 145 | 1260 | 915 | 52 |
| 3030 | 6000 kg | 555 | 130 | 370 | 290 | 130 | 185 | 1600 | 915 | 80 |

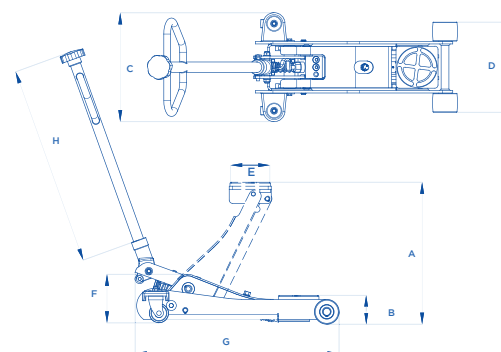



CLASSIC LINE BLU

112/S - Portata 2000 kg

~~€ 594,00~~ - € 349,00

112/BS - Portata 3000 kg

~~€ 862,00~~ - € 514,00

112/DS - Portata 2000 kg

~~€ 962,00~~ - € 574,00

| ART. | | A mm | B mm | C mm | D mm | E mm | F mm | G mm | H mm | KG |
|--------|---------|------|------|------|------|------|------|------|------|----|
| 112/S | 2000 kg | 525 | 135 | 345 | 290 | 100 | 200 | 650 | 780 | 36 |
| 112/BS | 3000 kg | 610 | 145 | 375 | 310 | 130 | 210 | 760 | 780 | 51 |
| 112/DS | 2000 kg | 800 | 145 | 370 | 300 | 130 | 210 | 950 | 780 | 60 |

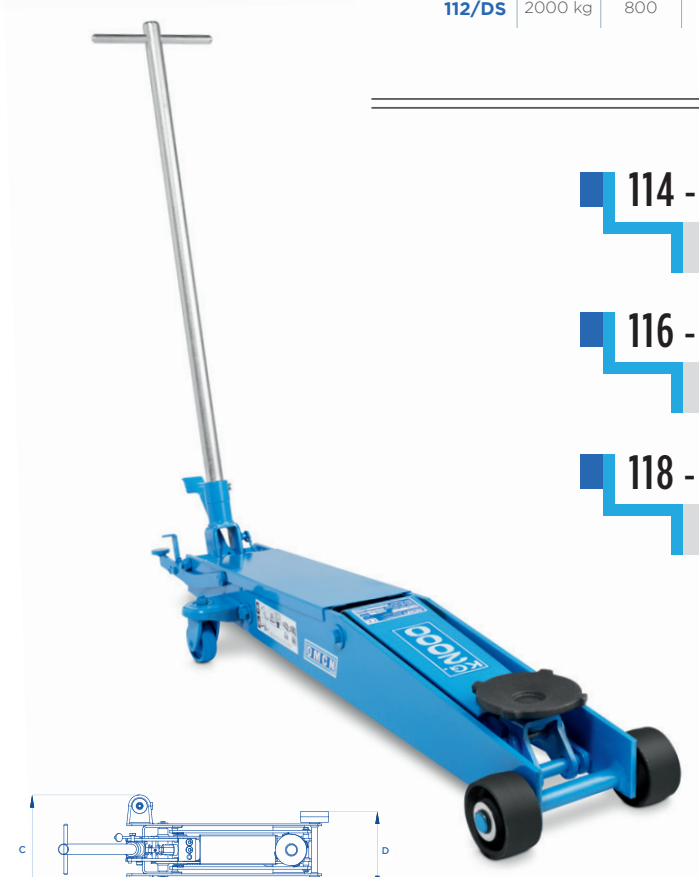

114 - Portata 2000 kg

~~€ 718,00~~ - € 428,00

116 - Portata 3000 kg

~~€ 831,00~~ - € 495,00

118 - Portata 5000 kg

~~€ 1.107,00~~ - € 660,00

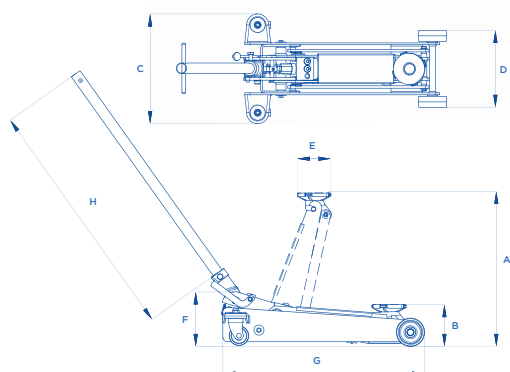

| ART. | | A mm | B mm | C mm | D mm | E mm | F mm | G mm | H mm | KG |
|------|---------|------|------|------|------|------|------|------|------|----|
| 114 | 2000 kg | 520 | 130 | 325 | 270 | 130 | 175 | 1260 | 920 | 52 |
| 116 | 3000 kg | 520 | 140 | 325 | 270 | 130 | 185 | 1280 | 920 | 56 |
| 118 | 5000 kg | 550 | 155 | 360 | 290 | 130 | 185 | 1530 | 920 | 80 |



CLASSIC LINE ROSSA

253 - Portata 2000 kg

~~€ 694,00~~ - € 413,00

254 - Portata 3000 kg

~~€ 953,00~~ - € 567,00

| ART. | | A mm | B mm | C mm | D mm | E mm | F mm | G mm | H mm | KG |
|------|---------|------|------|------|------|------|------|------|------|----|
| 253 | 2000 kg | 525 | 130 | 390 | 290 | 100 | 200 | 700 | 820 | 38 |
| 254 | 3000 kg | 610 | 140 | 395 | 310 | 130 | 225 | 760 | 820 | 54 |



262/S - Portata 5000 kg

~~€ 1.122,00~~ - € 667,00

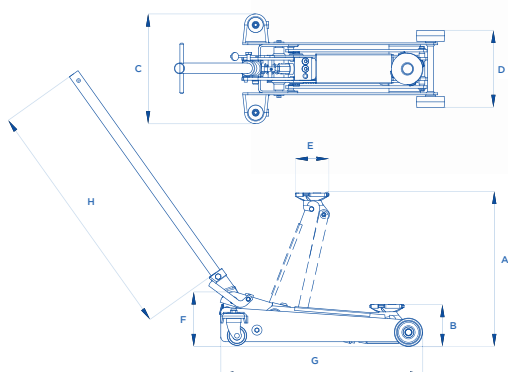

| ART. | | A mm | B mm | C mm | D mm | E mm | F mm | G mm | H mm | KG |
|-------|---------|------|------|------|------|------|------|------|------|----|
| 262/S | 5000 kg | 540 | 145 | 370 | 290 | 130 | 190 | 1485 | 920 | 83 |

SPECIAL LINE

1120/E - Portata 2000 kg

~~€ 1.323,00~~ - € 780,00

1120/F - Portata 2000 kg

~~€ 1.010,00~~ - € 595,00

I Doppi rulli anteriori basculanti e le ruote posteriori girevoli in poliuretano, consentono di poter muovere i sollevatori anche sui grigliati e sono particolarmente indicati per interventi in fase di soccorsi stradali.



112/XR - Portata 2000 kg

~~€ 782,00~~ - € 459,00

Completo di sicurezze meccaniche, ruote in nylon e supporto in acciaio ricoperto in gomma.



1130/XR - Portata 1500 kg

~~€ 979,00~~ - € 575,00



OPTIONAL

TAMPONE IN GOMMA

392/A

per ART. 112/S-253-1120/F-1130/XR

392/B

per ART. 112/BS-112/DS-254-1120/E

392/C

per ART. 114-116

~~€ 78,00~~ - € 46,00



| ART. | | A mm | B mm | C mm | D mm | E mm | F mm | G mm | H mm | KG |
|---------|---------|------|------|------|------|------|------|------|------|----|
| 1120/E | 2000 kg | 760 | 130 | 480 | 480 | 130 | 200 | 1080 | 910 | 65 |
| 1120/F | 2000 kg | 520 | 140 | 420 | 420 | 130 | 180 | 740 | 780 | 45 |
| 112/XR | 2000 kg | 525 | 120 | 350 | 290 | 130 | 215 | 650 | 780 | 35 |
| 1130/XR | 1500 kg | 510 | 100 | 360 | 205 | 100 | | 1320 | 780 | 50 |

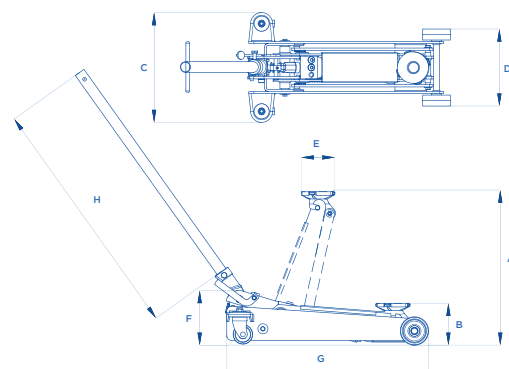

- Stelo in acciaio speciale rettificato e cromato.
- Ruote di grandi dimensioni montate su cuscinetti per la massima manovrabilità.
- Valvola di protezione contro i sovraccarichi.
- Comando di discesa a velocità controllata "uomo presente".

SIF 1/73 - Portata 250 kg

~~€ 494,00~~ - € 289,00

SIF 1/A/73 - Portata 400 kg

~~€ 575,00~~ - € 339,00

SIF 2/A/73 - Portata 600 kg

~~€ 845,00~~ - € 495,00

SIF 2/73 - Portata 1000 kg

~~€ 966,00~~ - € 569,00

SIF 3/73 - Portata 1500 kg

~~€ 1.064,00~~ - € 625,00

SIF 4/73 - Portata 2500 kg

~~€ 2.152,00~~ - € 1.270,00

SIF 7/73 - Portata 800 kg

~~€ 1.851,00~~ - € 1.092,00

SIF 8/73 - Portata 1500 kg

~~€ 2.212,00~~ - € 1.305,00

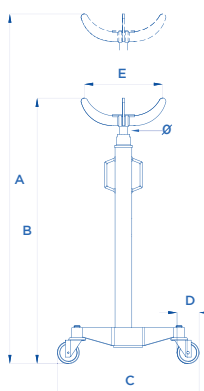

| ART. | | A mm | B mm | C mm | D mm | E mm | Ø mm | KG |
|----------------------------|---------|------|------|---------|------|------|------|----|
| SIF1/73 | 250 Kg | 2090 | 1240 | 635x635 | 80 | 270 | 22 | 22 |
| SIF1/A/73 | 400 Kg | 2090 | 1300 | 635x635 | 80 | 270 | 24 | 27 |
| SIF2/A/73 | 600 Kg | 1960 | 1180 | 520x520 | 80 | 320 | 30 | 37 |
| SIF2/73 | 1000 Kg | 1990 | 1190 | 530x530 | 100 | 325 | 35 | 40 |
| SIF3/73 | 1500 Kg | 2020 | 1220 | 540x540 | 100 | 340 | 45 | 60 |
| SIF4/73 | 2500 Kg | 2220 | 1350 | 550x550 | 100 | 355 | 50 | 85 |
| A DUE STADI SIF7/73 | 800 Kg | 1880 | 920 | 530x530 | 100 | 320 | 30 | 48 |
| SIF8/73 | 1500 Kg | 1960 | 960 | 550x550 | 100 | 325 | 35 | 58 |

CULLE UNIVERSALI



15/73 - Portata 250 kg

~~€ 247,00~~ - € 145,00

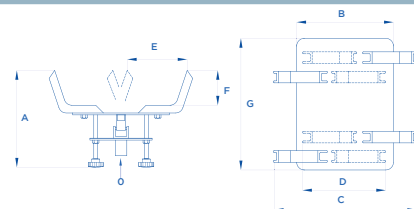

| ART. | | A mm | B mm | C mm | D mm | E mm | F mm | G mm | Ø mm | KG |
|--------------|--------|------|------|------|------|------|------|------|------|----|
| 15/73 | 250 kg | 360 | 250 | 525 | 420 | 80 | 100 | 340 | 30 | 15 |



234 - Portata 600 kg

~~€ 639,00~~ - € 376,00

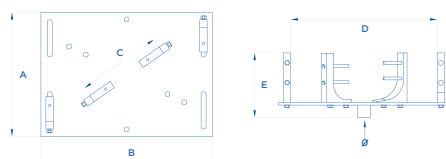

| ART. | | A mm | B mm | C mm | D mm | E mm | Ø mm | KG |
|------------|--------|------|------|------|------|------|------|----|
| 234 | 600 kg | 500 | 690 | 450 | 610 | 330 | 60 | 30 |

SIF/XR - Portata 100 kg

€ ~~1.241,00~~ - € **729,00**

ART. SIF/XR

Sollevatore creato per smontare e rimontare in tutta sicurezza ruote di autovetture, veicoli commerciali e SUV posti su ponti sollevatori a due colonne o doppia forbice.

L'azionamento è a pedale.

I rulli in materiale speciale sono registrabili in larghezza ed eccentrici per permettere il rapido posizionamento dei bulloni.

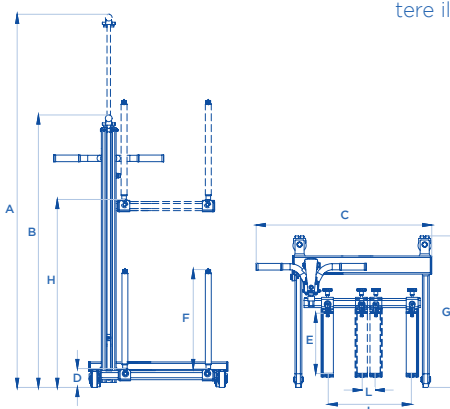

| | | | | | | | | | | | | |
|--------|--------|------|------|-----|-----|-----|-----|-----|-----|-----|----|----|
| ART. | | | | | | | | | | | | |
| SIF/XR | 100 kg | 2080 | 1230 | 770 | 100 | 295 | 425 | 730 | 940 | 355 | 45 | 50 |



SIF/XR IP - Portata 100 kg

€ ~~1.865,00~~ - € **1.100,00**

SIF/XR IP

Sollevatore creato per smontare e rimontare in tutta sicurezza ruote di autovetture, veicoli commerciali e SUV posti su ponti sollevatori a due colonne o doppia forbice.

L'azionamento è pneumatico.

I rulli in materiale speciale sono registrabili in larghezza ed eccentrici per permettere il rapido posizionamento dei bulloni.

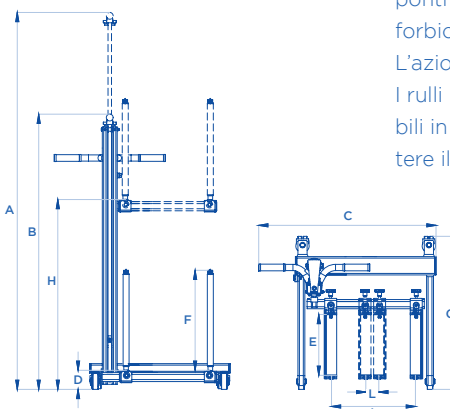

| | | | | | | | | | | | | | |
|-----------|--------|------------|------|------|-----|-----|-----|-----|-----|-----|-----|----|----|
| ART. | | | | | | | | | | | | | |
| SIF/XR IP | 100 kg | 8 - 10 bar | 2100 | 1250 | 750 | 100 | 295 | 425 | 760 | 940 | 355 | 45 | 60 |

- Lo stelo rettificato e cromato garantisce un'alta affidabilità nel tempo.
- Braccio allungabile in quattro posizioni di lavoro.
- Ruote posteriori girevoli per la massima manovrabilità.
- Gancio girevole a 360°.
- Dotata di tiranti laterali.
- Valvola di protezione contro i sovraccarichi incorporata.
- Comando di discesa a velocità controllata.
- Pompa idraulica ad una velocità (131 - 132).
- Pompa idraulica a due velocità (133 - 134).
- Dotata di ruote in gomma (131 - 133).
- Dotata di ruote in gomma e nylon (132 - 134).

131 - Portata 500 kg

€ ~~886,00~~ - € **524,00**

132 - Portata 1000 kg

€ ~~1.301,00~~ - € **769,00**

133 - Portata 500 kg

€ ~~1.007,00~~ - € **595,00**

134 - Portata 1000 kg

€ ~~1.423,00~~ - € **841,00**

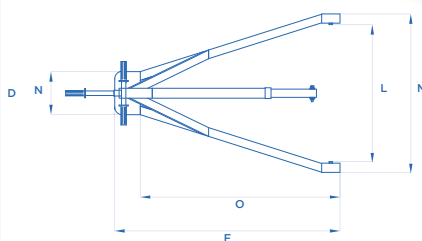
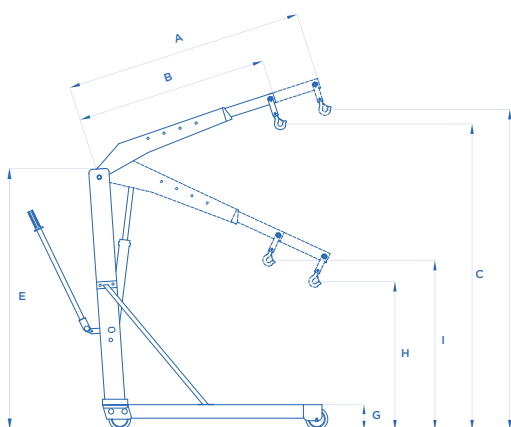

| ART. | | | | |
|------------------|---------|--------|--------|--------|
| 131 • 133 | 500 kg | 400 kg | 250 kg | 150 kg |
| 132 • 134 | 1000 Kg | 800 Kg | 500 Kg | 300 Kg |

| ART. | | A mm | B mm | C mm | D mm | E mm | F mm | G mm | H mm | I mm | L mm | M mm | N mm | O mm | KG |
|------|--|------|------|------|------|------|------|------|------|------|------|------|------|------|----|
|------|--|------|------|------|------|------|------|------|------|------|------|------|------|------|----|

| | | | | | | | | | | | | | | | |
|-------------|---------|------|------|------|------|------|------|-----|-----|-----|-----|------|-----|------|-----|
| 131* | 500 Kg | 1315 | 1015 | 2130 | 2355 | 1560 | 1295 | 160 | 435 | 660 | 785 | 900 | 600 | 1140 | 75 |
| 132* | 1000 Kg | 1540 | 1250 | 2390 | 2670 | 1720 | 1530 | 180 | 470 | 670 | 955 | 1075 | 745 | 1360 | 110 |
| 133 | 500 Kg | 1315 | 1015 | 2130 | 2355 | 1560 | 1295 | 160 | 435 | 660 | 785 | 900 | 600 | 1140 | 75 |
| 134 | 1000 Kg | 1540 | 1250 | 2390 | 2670 | 1720 | 1530 | 180 | 470 | 670 | 955 | 1075 | 745 | 1360 | 110 |

(*) Salvo esaurimento scorte

GRU IDRAULICHE A CARRELLO

24 MESI
GARANZIA

OMCN
S.p.A.

MADE IN ITALY

- Lo stelo rettificato e cromato garantisce un'alta affidabilità nel tempo.
- Braccio allungabile in quattro posizioni di lavoro.
- Ruote posteriori girevoli per la massima manovrabilità.
- Gancio girevole a 360°.
- Dotata di tiranti laterali.
- Valvola di protezione contro i sovraccarichi incorporata.
- Comando di discesa a velocità controllata.
- Pompa idraulica a due velocità.
- Dotata di ruote in poliuretano.



SL/15 - Portata 1500 kg

€ ~~2.192,00~~ - € **1.295,00**

SL/20 - Portata 2000 kg

€ ~~2.623,00~~ - € **1.550,00**

SL/30 - Portata 3000 kg

€ ~~4.971,00~~ - € **2.930,00**

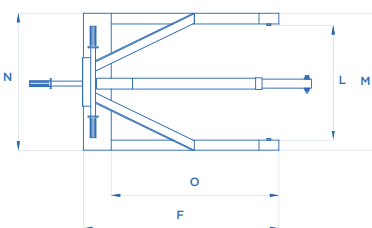
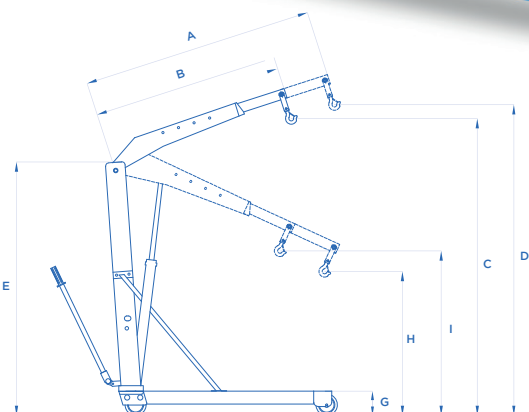

| ART. | | | | |
|--------------|---------|---------|---------|---------|
| SL/15 | 1500 Kg | 1200 Kg | 800 Kg | 500 Kg |
| SL/20 | 2000 Kg | 1500 Kg | 1000 Kg | 600 Kg |
| SL/30 | 3000 Kg | 2400 Kg | 1850 Kg | 1300 Kg |

| ART. | | A mm | B mm | C mm | D mm | E mm | F mm | G mm | H mm | I mm | L mm | M mm | N mm | O mm | KG |
|--------------|---------|------|------|------|------|------|------|------|------|------|------|------|------|------|-----|
| SL/15 | 1500 Kg | 1815 | 1370 | 2470 | 2750 | 1865 | 1690 | 195 | 310 | 630 | 830 | 1015 | 1000 | 1450 | 190 |
| SL/20 | 2000 Kg | 1910 | 1460 | 2780 | 3110 | 1990 | 1910 | 215 | 315 | 645 | 940 | 1120 | 1100 | 1640 | 235 |
| SL/30 | 3000 Kg | 2280 | 1790 | 3300 | 3730 | 2150 | 2270 | 265 | 510 | 780 | 1170 | 1420 | 1400 | 1910 | 480 |

135 - Portata 500 kg

€ ~~1.347,00~~ - € **796,00**

136 - Portata 1000 kg

€ ~~1.870,00~~ - € **1.105,00**

137 - Portata 1500 kg

€ ~~2.659,00~~ - € **1.572,00**

138 - Portata 2000 kg

€ ~~3.222,00~~ - € **1.900,00**

138/A - Portata 2500 kg

€ ~~3.950,00~~ - € **2.329,00**

- Lo stelo rettificato e cromato garantisce un'alta affidabilità nel tempo.
- Braccio allungabile in quattro posizioni di lavoro.
- Ruote posteriori girevoli per la massima manovrabilità.
- Gancio girevole a 360°.
- Valvola di protezione contro i sovraccarichi incorporata.
- Comando di discesa a velocità controllata.
- Pompa idraulica a due velocità.
- Dotata di ruote in gomma (135).
- Dotata di ruote in gomma e poliuretano (136).
- Dotata di ruote in poliuretano (137 - 138 - 138/A).



137 • 138 • 138/A

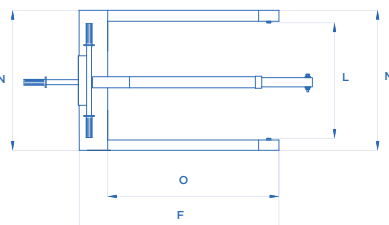
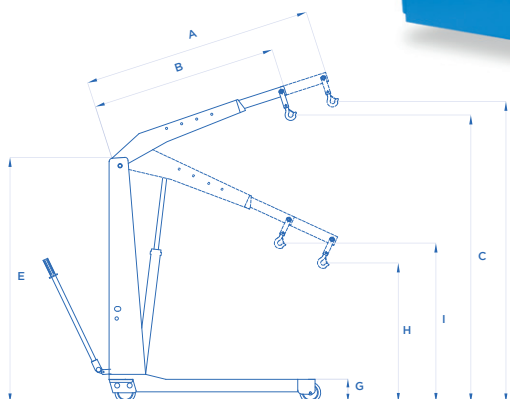

| ART. | | | | |
|--------------|---------|---------|---------|---------|
| 135 | 500 Kg | 400 kg | 250 kg | 150 kg |
| 136 | 1000 Kg | 800 Kg | 500 Kg | 300 Kg |
| 137 | 1500 Kg | 1200 Kg | 800 Kg | 500 Kg |
| 138 | 2000 Kg | 1500 Kg | 1000 Kg | 600 Kg |
| 138/A | 2500 Kg | 2000 Kg | 1500 Kg | 1000 Kg |

| ART. | | A mm | B mm | C mm | D mm | E mm | F mm | G mm | H mm | I mm | L mm | M mm | N mm | O mm | KG |
|--------------|---------|------|------|------|------|------|------|------|------|------|------|------|------|------|-----|
| 135 | 500 Kg | 1315 | 1010 | 2260 | 2490 | 1700 | 1370 | 155 | 520 | 745 | 650 | 805 | 800 | 1075 | 102 |
| 136 | 1000 Kg | 1550 | 1250 | 2485 | 2695 | 1830 | 1520 | 165 | 560 | 760 | 790 | 960 | 960 | 1195 | 150 |
| 137 | 1500 Kg | 1825 | 1370 | 2680 | 3010 | 1935 | 1810 | 185 | 310 | 650 | 960 | 1145 | 1140 | 1415 | 250 |
| 138 | 2000 Kg | 1910 | 1460 | 2900 | 3300 | 2055 | 1915 | 213 | 510 | 795 | 1150 | 1350 | 1340 | 1480 | 315 |
| 138/A | 2500 Kg | 2010 | 1565 | 3020 | 3390 | 2085 | 2085 | 230 | 460 | 760 | 1180 | 1405 | 1390 | 1610 | 360 |

GRU IDRAULICHE A CARRELLO PIEGHEVOLI

24 MESI
GARANZIA

OMCN
S.p.A.

MADE IN ITALY

- Pieghevoli in pochi secondi, ingombro irrilevante in fase di riposizione.
- Lo stelo rettificato e cromato garantisce un'alta affidabilità nel tempo.
- Braccio allungabile in quattro posizioni di lavoro.
- Ruote posteriori girevoli per la massima manovrabilità.
- Gancio girevole a 360°.
- Valvola di protezione contro i sovraccarichi incorporata.
- Comando di discesa a velocità controllata.
- Pompa idraulica a due velocità.



GP05/DE - Portata 500 kg

€ 1.071,00 - € 630,00

GP10/DE - Portata 1000 kg

€ 1.507,00 - € 890,00



GP12/DE - Portata 1200 kg

€ 1.962,00 - € 1.160,00

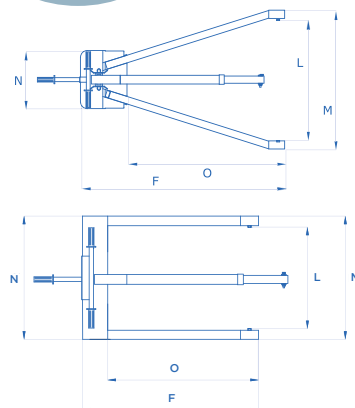
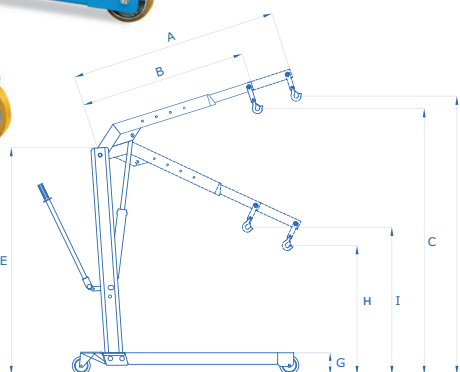
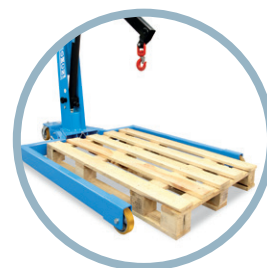

| ART. | | | | |
|---------|---------|--------|--------|--------|
| GP05/DE | 500 Kg | 400 Kg | 250 Kg | 150 Kg |
| GP10/DE | 1000 Kg | 800 Kg | 500 Kg | 300 Kg |
| GP12/DE | 1200 Kg | 900 Kg | 800 Kg | 700 Kg |

| ART. | | A mm | B mm | C mm | D mm | E mm | F mm | G mm | H mm | I mm | L mm | M mm | N mm | O mm | KG |
|---------|---------|------|------|------|------|------|------|------|------|------|------|------|------|------|-----|
| GP05/DE | 500 Kg | 1300 | 1000 | 2130 | 2360 | 1570 | 1540 | 150 | 400 | 600 | 780 | 900 | 400 | 1160 | 80 |
| GP10/DE | 1000 Kg | 1470 | 1170 | 2180 | 2320 | 1700 | 1740 | 180 | 550 | 725 | 840 | 980 | 450 | 1325 | 122 |
| GP12/DE | 1200 Kg | 1490 | 1190 | 2140 | 2355 | 1600 | 1600 | 135 | 620 | 800 | 1005 | 1170 | 1150 | 1110 | 125 |

- Compatta struttura in robusto acciaio saldato.
- Stelo del cilindro in acciaio speciale, trattato e cromato.
- Molla in acciaio inserita nel cilindro per un rapido ritorno dello stelo.
- Pompa a mano a due velocità: rapidità in fase di avvicinamento e precisione in fase di lavoro (153).
- Gestione delle due velocità tramite volantino posto sulla pompa (153).
- Pompa a mano ad una velocità (152).
- Massima versatilità grazie al bancale ad altezza regolabile (153).
- Piatto cacciaspine e coppia di prismi a V forniti di serie (153).

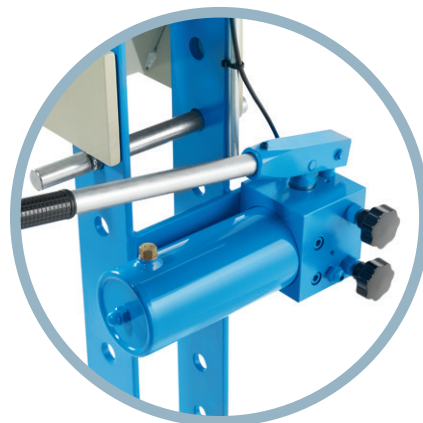

152 - Portata 6 Ton.

€ ~~755,00~~ - € 445,00



153 - Portata 10 Ton.

€ ~~1.443,00~~ - € 850,00

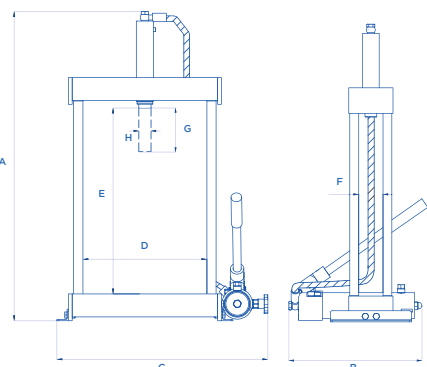

| ART. | TON | A mm | B mm | C mm | D mm | E mm | F mm | G mm | H mm | KG |
|------|-----|------|------|------|------|------|------|------|------|-----|
| 152 | 6 | 820 | 470 | 550 | 320 | 495 | 67 | 115 | 32 | 43 |
| 153 | 10 | 1210 | 500 | 895 | 520 | 370 | 120 | 190 | 40 | 104 |

PRESSE IDRAULICHE CON POMPA A MANO

24 MESI
GARANZIA

OMCN
S.p.A.

MADE IN ITALY

- Stelo del cilindro in acciaio speciale, trattato e cromato.
- **Molla in acciaio inserita nel cilindro per un rapido ritorno dello stelo.**
- Pompa a mano a due velocità: rapidità in fase di avvicinamento e precisione in fase di lavoro (154 - 155 - 156).
- Gestione delle due velocità tramite volantino posto sulla pompa (154 - 155 - 156).
- Pompa a mano ad una velocità (154/E).
- Massima versatilità grazie al bancale ad altezza regolabile.
- Piatto cacciaspine e coppia di prismi a V forniti di serie (154 - 155 - 156).

154/E - Portata 10 Ton.

PIATTI E PRISMI ESCLUSI

~~€ 1.315,00~~ - € 775,00

154 - Portata 10 Ton.

~~€ 1.683,00~~ - € 992,00

155 - Portata 15 Ton.

~~€ 1.892,00~~ - € 1.115,00

156 - Portata 20 Ton.

~~€ 2.197,00~~ - € 1.294,00

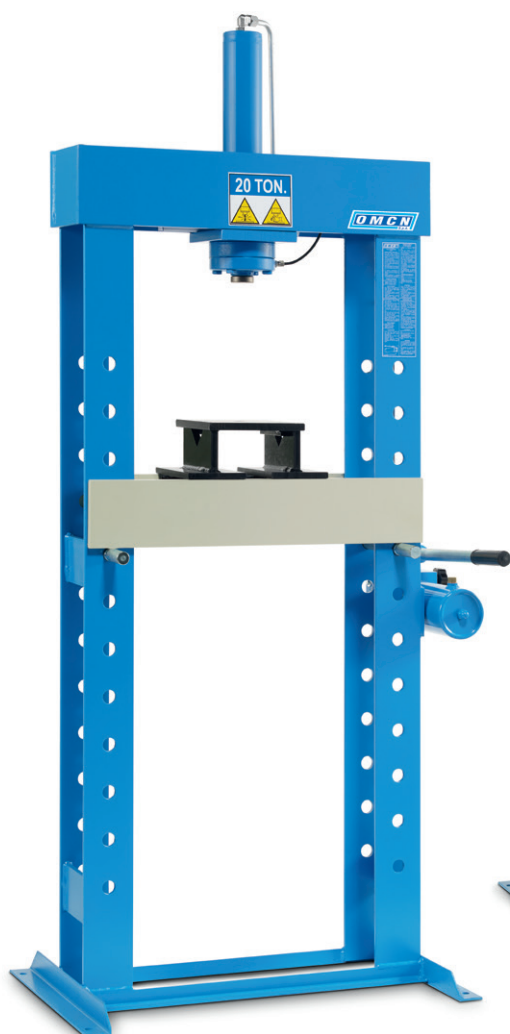

ART. 156

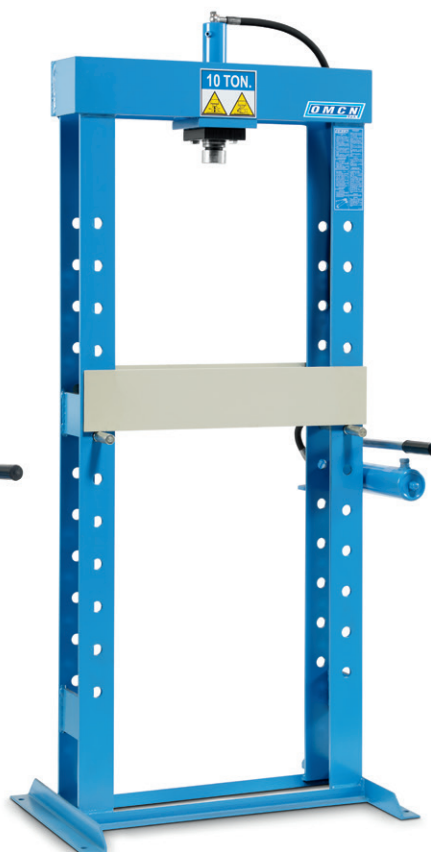

ART. 154/E

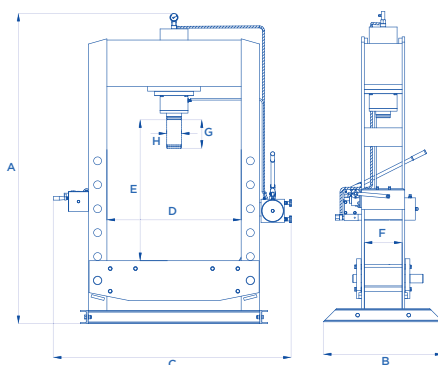

| ART. | TON | A mm | B mm | C mm | D mm | E mm | F mm | G mm | H mm | KG |
|--------|-----|------|------|------|------|------|------|------|------|-----|
| 154/E* | 10 | 1910 | 500 | 870 | 520 | 980 | 120 | 160 | 40 | 94 |
| 154 | 10 | 1900 | 500 | 910 | 515 | 980 | 120 | 190 | 40 | 124 |
| 155 | 15 | 1930 | 500 | 930 | 510 | 1020 | 140 | 190 | 40 | 130 |
| 156 | 20 | 1960 | 500 | 930 | 510 | 1020 | 140 | 200 | 50 | 150 |

(*) Salvo esaurimento scorte

- Struttura in robusto acciaio saldato.
- Stelo del cilindro in acciaio speciale, trattato e cromato.
- Molla in acciaio inserita nel cilindro per un rapido ritorno dello stelo.
- **Pompa a mano a due velocità: rapidità in fase di avvicinamento e precisione in fase di lavoro.**
- Gestione delle due velocità tramite volantino posto sulla pompa.
- Complete di argano per poter sollevare il bancale in modo pratico e veloce.
- Manometro di grosso diametro fornito di serie.

P30/SA - Portata 30 Ton.

~~€ 3.571,00~~ - € 2.095,00

158 - Portata 50 Ton.

~~€ 5.334,00~~ - € 3.147,00

159 - Portata 70 Ton.

~~€ 8.276,00~~ - € 4.883,00

160 - Portata 100 Ton.

~~€ 10.136,00~~ - € 5.981,00

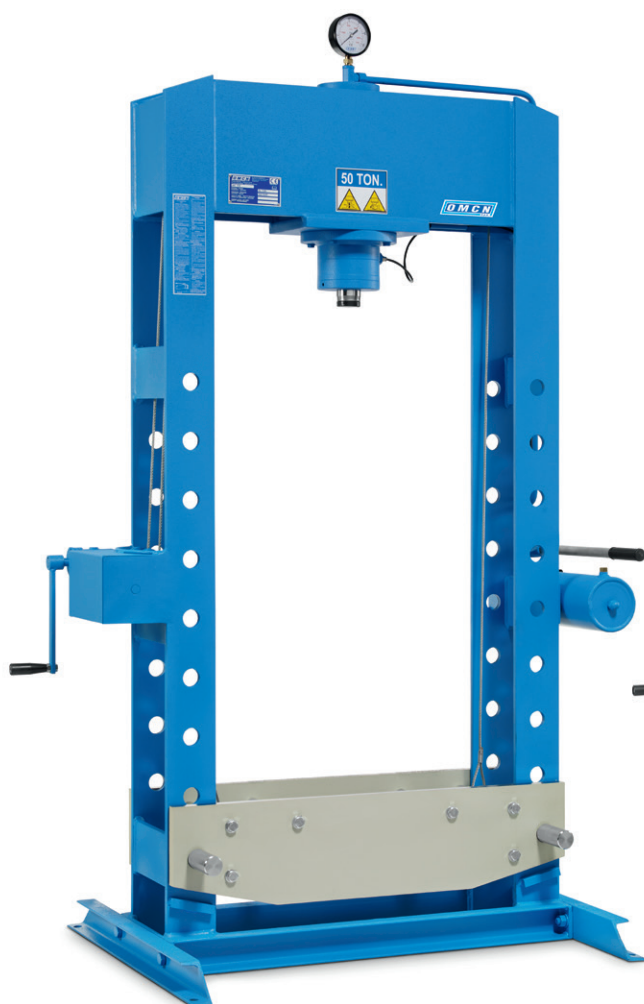

ART. 158

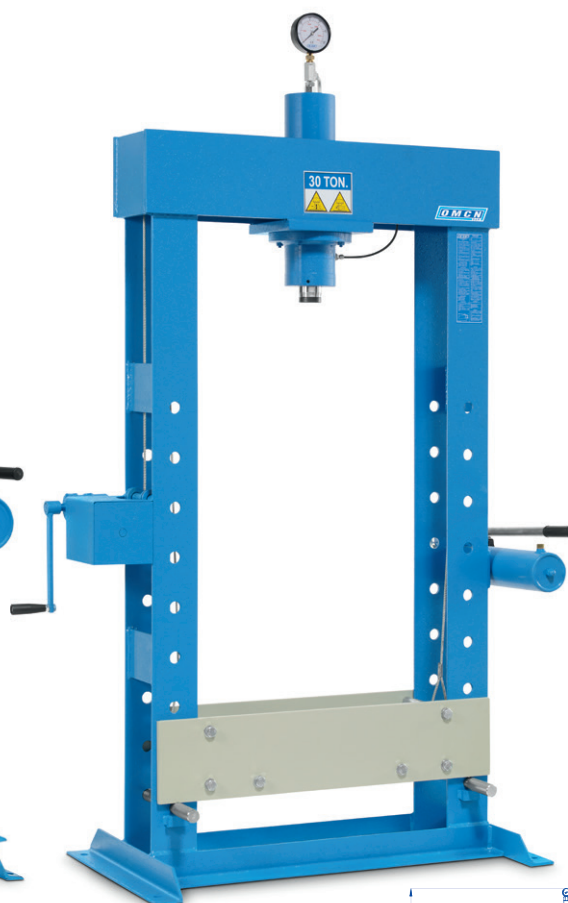

ART. P30/SA

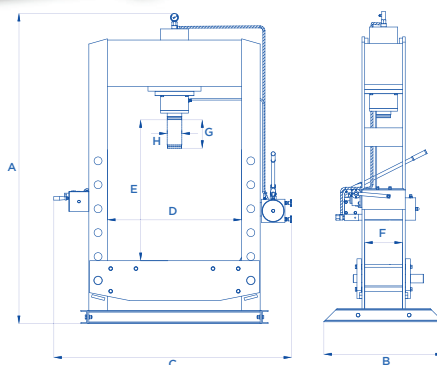

| ART. | TON | A mm | B mm | C mm | D mm | E mm | F mm | G mm | H mm | KG |
|--------|-----|------|------|------|------|------|------|------|------|-----|
| P30/SA | 30 | 2180 | 600 | 1300 | 695 | 1000 | 170 | 190 | 60 | 280 |
| 158 | 50 | 2260 | 850 | 1420 | 770 | 1135 | 210 | 190 | 60 | 455 |
| 159 | 70 | 2340 | 900 | 1580 | 880 | 1120 | 270 | 210 | 90 | 700 |
| 160 | 100 | 2440 | 900 | 1740 | 1010 | 1055 | 285 | 215 | 110 | 960 |

- Stelo del cilindro in acciaio speciale, trattato e cromato.
- Molla in acciaio inserita nel cilindro per un rapido ritorno dello stelo.
- **La pompa idropneumatica a pedale consente di lavorare avendo entrambe le mani libere.**
- Massima versatilità grazie al bancale ad altezza regolabile.
- Complete di argano per poter sollevare il bancale in modo pratico e veloce (P30/SAIP - 157/IP - 158/IP).
- Piatto cacciaspine e coppia di prismi a V forniti di serie (154/IP - 155/IP - 156/IP).
- Manometro di grosso diametro fornito di serie (P30/SAIP - 157/IP - 158/IP).

154/IP - Portata 10 Ton.

~~€ 2.337,00~~ - € 1.377,00

155/IP - Portata 15 Ton.

~~€ 2.529,00~~ - € 1.490,00

156/IP - Portata 20 Ton.

~~€ 2.861,00~~ - € 1.686,00

P30/SAIP - Portata 30 Ton.

~~€ 4.626,00~~ - € 2.730,00

157/IP - Portata 40 Ton.

~~€ 5.885,00~~ - € 3.473,00

158/IP - Portata 50 Ton.

~~€ 6.466,00~~ - € 3.815,00

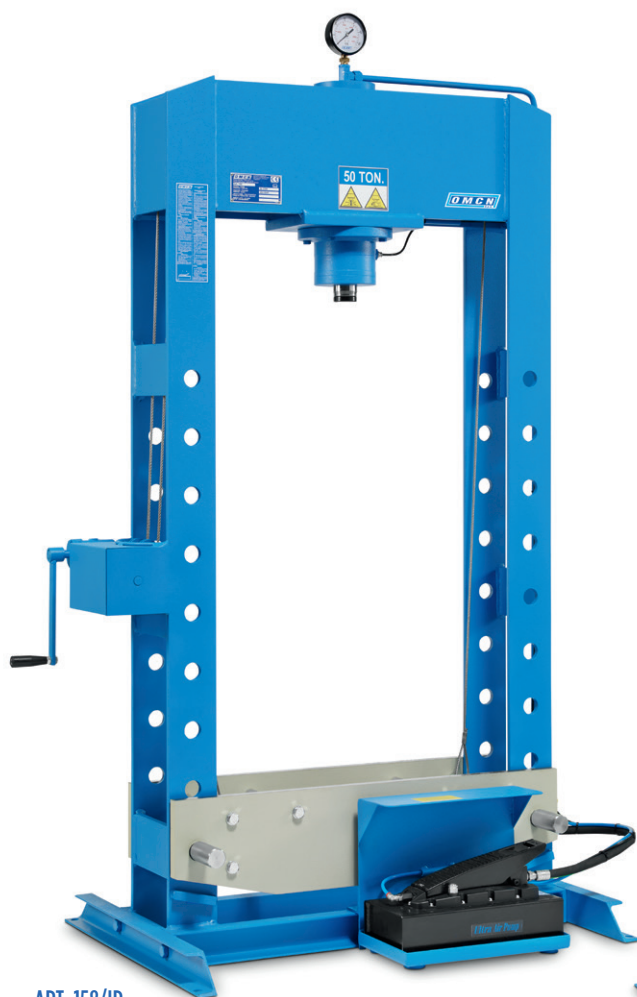

ART. 158/IP

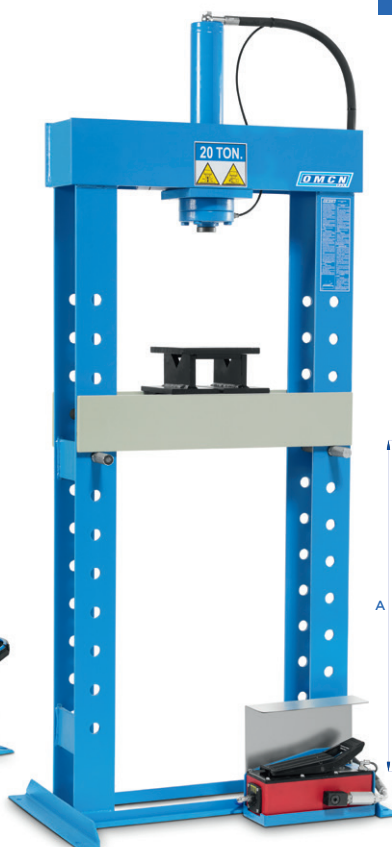

ART. 156/IP

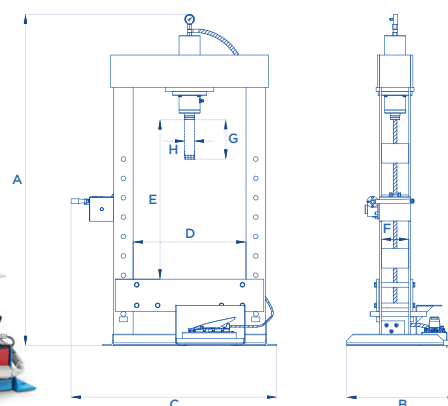

| ART. | TON | | | A | B | C | D | E | F | G | H | |
|-----------------|-----|------|--------|------|-----|------|-----|------|-----|-----|----|-----|
| | | bar | mm/min | mm | mm | mm | mm | mm | mm | mm | mm | KG |
| 154/IP | 10 | 6-8 | 450 | 1910 | 500 | 780 | 520 | 980 | 120 | 190 | 40 | 124 |
| 155/IP | 15 | 6-8 | 450 | 1930 | 500 | 790 | 510 | 1020 | 140 | 190 | 40 | 130 |
| 156/IP | 20 | 6-8 | 330 | 1960 | 500 | 810 | 510 | 1020 | 140 | 200 | 50 | 150 |
| P30/SAIP | 30 | 6-10 | 170 | 2170 | 600 | 1270 | 695 | 1000 | 170 | 190 | 60 | 280 |
| 157/IP* | 40 | 6-10 | 170 | 2260 | 850 | 1330 | 770 | 1135 | 200 | 190 | 60 | 405 |
| 158/IP | 50 | 6-10 | 120 | 2260 | 850 | 1330 | 770 | 1135 | 210 | 190 | 60 | 445 |

(*) Salvo esaurimento scorte

- Stelo del cilindro in acciaio speciale, trattato e cromato.
- Molla in acciaio inserita nel cilindro per un rapido ritorno dello stelo.
- La pompa a pedale consente di lavorare avendo entrambe le mani libere.
- **Pompa a due velocità: rapidità in fase di avvicinamento e precisione in fase di lavoro.**
- Massima versatilità grazie al bancale ad altezza regolabile.
- Completa di argano per poter sollevare il bancale in modo pratico e veloce (P30/SAP).
- Piano cacciaspine e coppia di prismi a V forniti di serie (154/P - 155/P - 156/P).
- Manometro di grosso diametro fornito di serie (P30/SAP).

154/P - Portata 10 Ton.

~~€ 1.994,00~~ - € 1.175,00

155/P - Portata 15 Ton.

~~€ 2.214,00~~ - € 1.305,00

156/P - Portata 20 Ton.

~~€ 2.559,00~~ - € 1.508,00

P30/SAP - Portata 30 Ton.

~~€ 4.176,00~~ - € 2.464,00

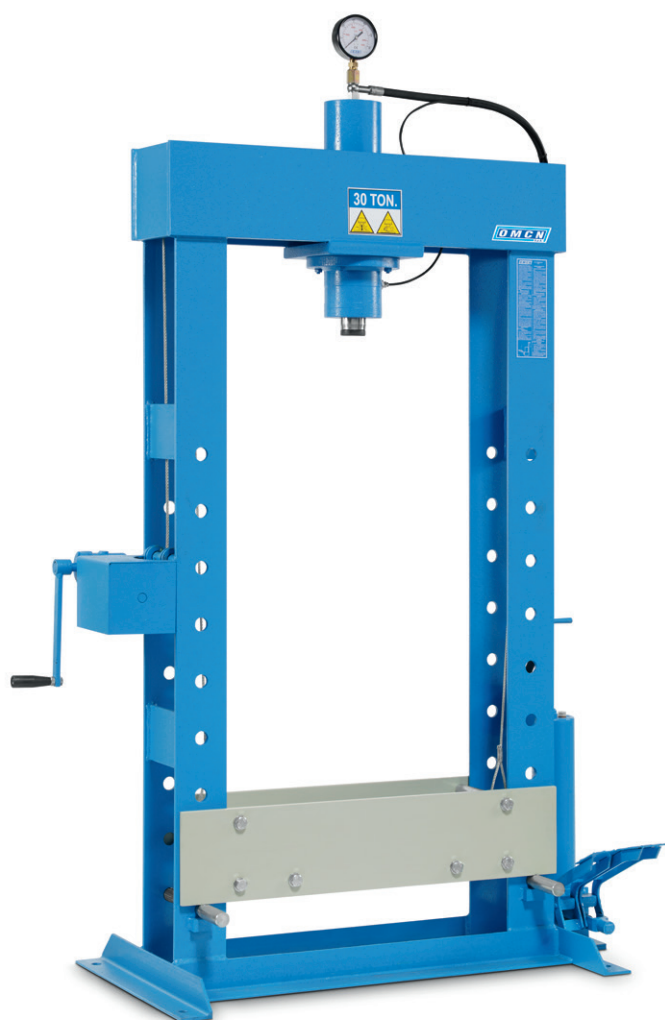

ART. P30/SAP

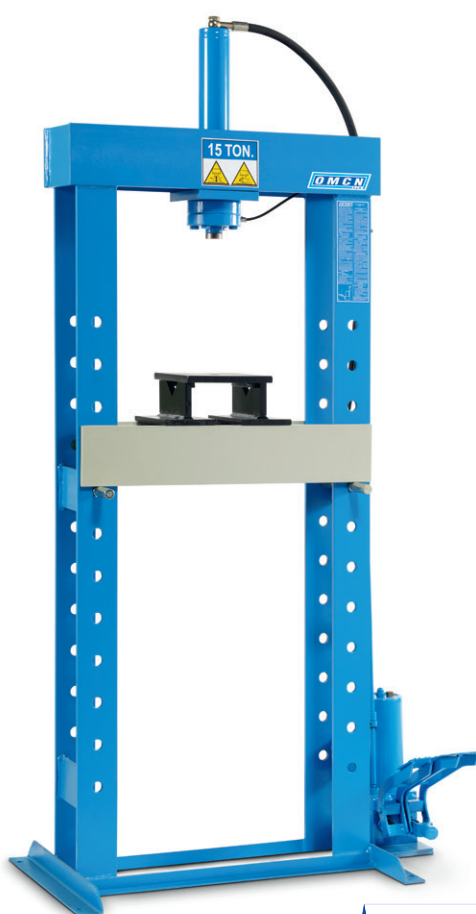

ART. 155/P

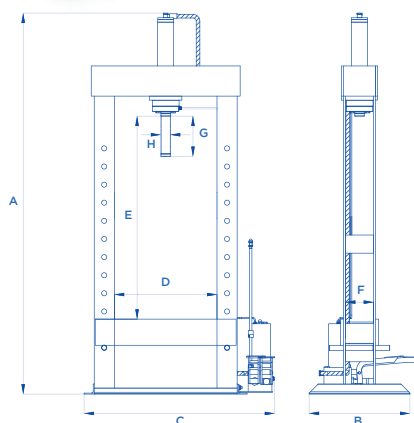

| ART. | TON | A mm | B mm | C mm | D mm | E mm | F mm | G mm | H mm | KG |
|---------|-----|------|------|------|------|------|------|------|------|-----|
| 154/P | 10 | 1910 | 500 | 910 | 520 | 980 | 120 | 190 | 40 | 124 |
| 155/P | 15 | 1930 | 500 | 930 | 510 | 1020 | 140 | 190 | 40 | 130 |
| 156/P | 20 | 1960 | 500 | 930 | 510 | 1020 | 140 | 200 | 50 | 150 |
| P30/SAP | 30 | 2170 | 600 | 1300 | 695 | 1000 | 170 | 190 | 60 | 280 |

- Stelo del cilindro in acciaio speciale, trattato e cromato.
- **Centralina motorizzata ad una velocità.**
- Azionamento tramite distributore a leva a 3 posizioni. Questa soluzione permette di avere una mano libera per lavorare.
- Dotate di valvola di taratura per regolare la potenza in base alla lavorazione da eseguire.
- Massima versatilità grazie al bancale ad altezza regolabile.
- Complete di argano per poter sollevare il bancale in modo pratico e veloce (escluso 154/ML - 156/ML).
- Manometro fornito di serie.



154/ML - Portata 10 Ton.

€ ~~4.405,00~~ - € **2.599,00**

156/ML - Portata 20 Ton.

€ ~~5.287,00~~ - € **3.120,00**

P30/ML - Portata 30 Ton.

€ ~~6.254,00~~ - € **3.690,00**

161 - Portata 40 Ton.

€ ~~7.858,00~~ - € **4.637,00**

162 - Portata 50 Ton.

€ ~~8.463,00~~ - € **4.993,00**

163 - Portata 70 Ton.

€ ~~11.398,00~~ - € **6.725,00**

164 - Portata 100 Ton.

€ ~~12.647,00~~ - € **7.462,00**

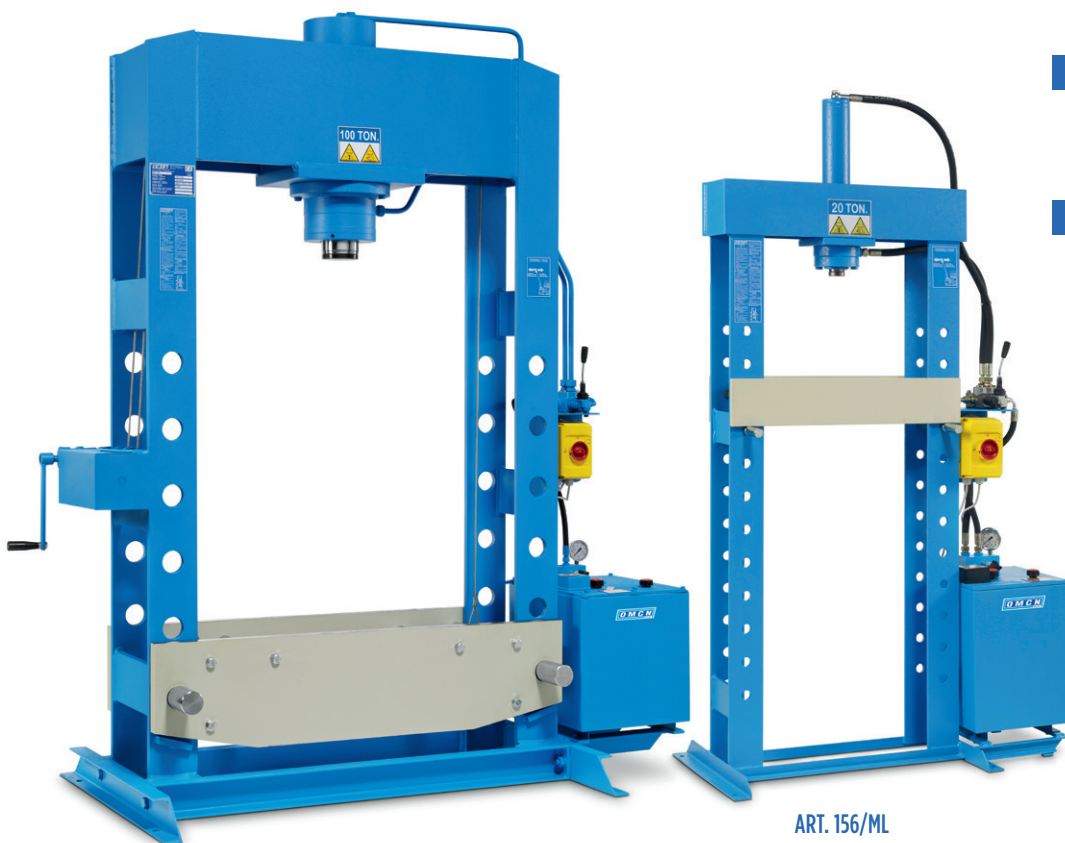

ART. 164

ART. 156/ML

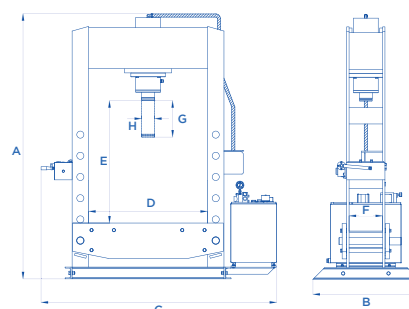

| ART. | TON | mm/min | A mm | B mm | C mm | D mm | E mm | F mm | G mm | H mm | | KG |
|---------------|-----|--------|------|------|------|------|------|------|------|------|--------|------|
| 154/ML | 10 | 570 | 1910 | 500 | 1100 | 520 | 980 | 120 | 260 | 40 | 1,5 kw | 174 |
| 156/ML | 20 | 300 | 1960 | 500 | 1110 | 510 | 1000 | 140 | 285 | 50 | 1,5 kw | 190 |
| P30/ML | 30 | 300 | 2020 | 600 | 1600 | 695 | 1000 | 170 | 260 | 60 | 1,5 kw | 320 |
| 161* | 40 | 300 | 2130 | 850 | 1575 | 770 | 1135 | 200 | 260 | 60 | 1,5 kw | 440 |
| 162 | 50 | 210 | 2130 | 850 | 1570 | 770 | 1135 | 210 | 260 | 60 | 1,5 kw | 480 |
| 163 | 70 | 260 | 2210 | 900 | 1755 | 880 | 1120 | 270 | 310 | 90 | 3 kw | 740 |
| 164 | 100 | 180 | 2310 | 900 | 1930 | 1010 | 1055 | 285 | 310 | 110 | 3 kw | 1000 |

(*) Salvo esaurimento scorte

- Stelo del cilindro in acciaio speciale, trattato e cromato.
- Centralina motorizzata a due velocità ad inserimento automatico (escluso 156/W - P30/W - 161/W).
- **Azionamento tramite distributore a leva a 3 posizioni. Questa soluzione permette di avere una mano libera per lavorare.**
- Dotate di valvola di taratura per regolare la potenza in base alla lavorazione da eseguire.
- Massima versatilità grazie al bancale ad altezza regolabile.
- Sollevamento del bancale tramite apposito argano (P30/W - 161/W - 162/W - 163/W - 164/W).
- Manometro fornito di serie.

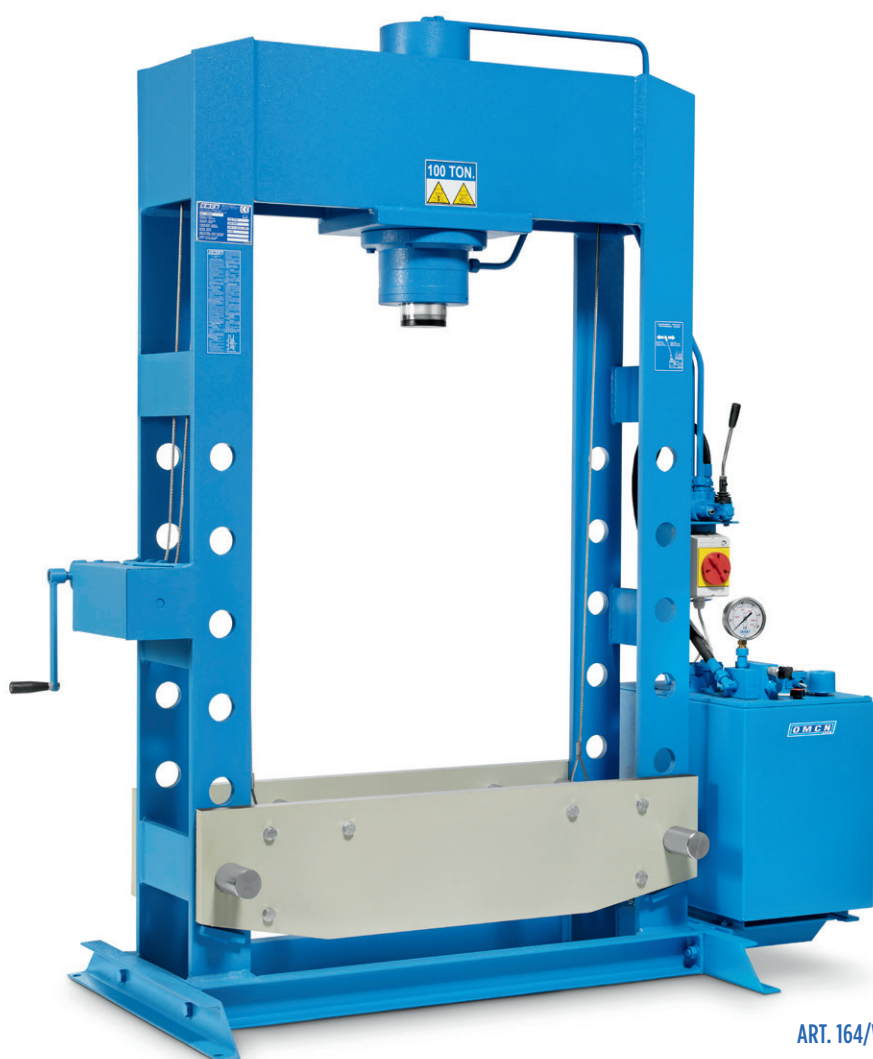

ART. 164/W

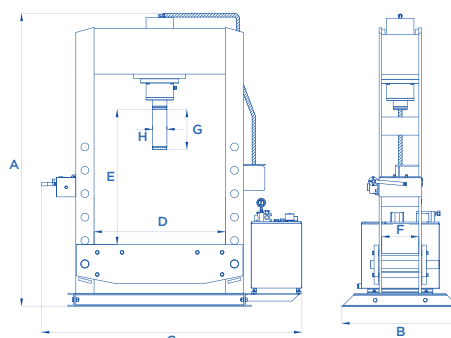

156/W - Portata 20 Ton.

~~€ 5.771,00~~ - € 3.402,00

P30/W - Portata 30 Ton.

~~€ 7.196,00~~ - € 4.241,00

161/W - Portata 40 Ton.

~~€ 8.741,00~~ - € 5.152,00

162/W - Portata 50 Ton.

~~€ 9.672,00~~ - € 5.700,00

163/W - Portata 70 Ton.

~~€ 12.884,00~~ - € 7.624,00

164/W - Portata 100 Ton.

~~€ 14.291,00~~ - € 8.456,00

| ART. | TON | | | | | | | | | | | | |
|---------------|-----|-----|-----|------|-----|------|------|------|-----|-----|-----|--------|------|
| 156/W | 20 | 450 | | 1960 | 500 | 1110 | 510 | 1000 | 140 | 285 | 50 | 1,5 kw | 200 |
| P30/W | 30 | 575 | | 2020 | 600 | 1600 | 695 | 1000 | 170 | 260 | 60 | 3 kw | 330 |
| 161/W* | 40 | 575 | | 2130 | 850 | 1650 | 775 | 1135 | 195 | 260 | 60 | 3 kw | 470 |
| 162/W | 50 | 600 | 215 | 2130 | 850 | 1650 | 775 | 1135 | 205 | 260 | 60 | 1,5 kw | 530 |
| 163/W | 70 | 595 | 260 | 2210 | 900 | 1755 | 880 | 1120 | 265 | 310 | 90 | 3 kw | 800 |
| 164/W | 100 | 570 | 180 | 2310 | 900 | 1930 | 1010 | 1055 | 280 | 310 | 110 | 3 kw | 1050 |

(*) Salvo esaurimento scorte

- Stelo del cilindro in acciaio speciale, trattato e cromato.
- Centralina motorizzata a due velocità ad inserimento automatico.
- **Funzionamento tramite distributore a leva e pulsante sul quadro da azionare contemporaneamente.**
- Complete di pannelli protettivi posteriore e laterali in acciaio zincato.
- Dotate di valvola di taratura per regolare la potenza in base alla lavorazione da eseguire.
- Massima versatilità grazie al bancale ad altezza regolabile.
- Sollevamento del bancale tramite apposito argano (P30/MR - 161/R - 162/R - 163/R - 164/R).
- Manometro fornito di serie.

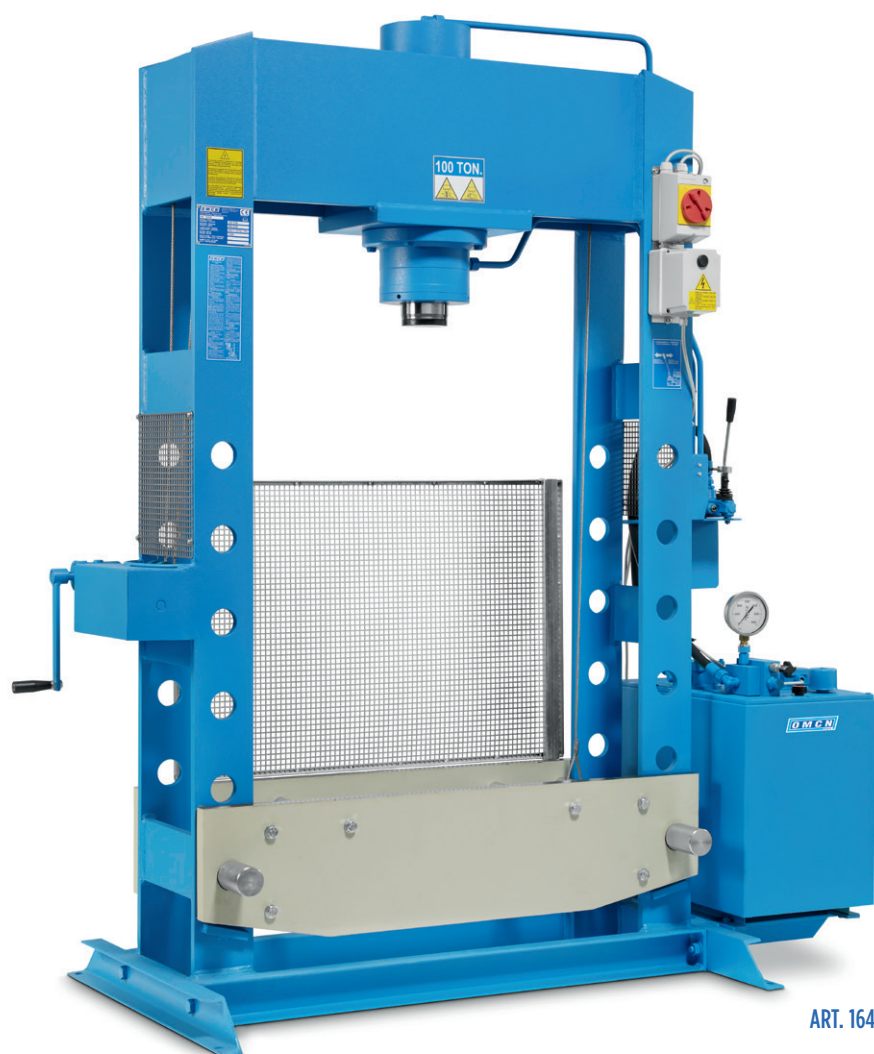

ART. 164/R

- 154/MR - Portata 10 Ton.**
~~€ 6.307,00~~ - € 3.717,00
- 156/MR - Portata 20 Ton.**
~~€ 1.217,00~~ - € 4.254,00
- P30/MR - Portata 30 Ton.**
~~€ 8.351,00~~ - € 4.922,00
- 161/R - Portata 40 Ton.**
~~€ 9.899,00~~ - € 5.834,00
- 162/R - Portata 50 Ton.**
~~€ 10.518,00~~ - € 6.224,00
- 163/R - Portata 70 Ton.**
~~€ 13.822,00~~ - € 8.179,00
- 164/R - Portata 100 Ton.**
~~€ 15.072,00~~ - € 8.919,00

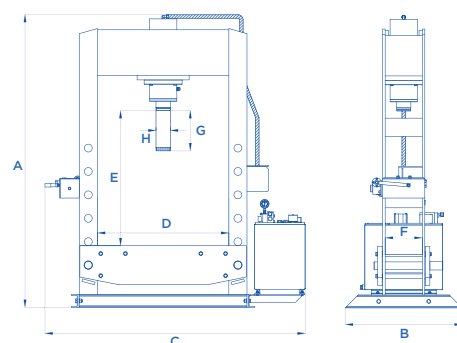

| ART. | TON | | | A | B | C | D | E | F | G | H | | |
|---------------|-----|--------|--------|------|-----|------|------|------|-----|-----|-----|---------|------|
| | | mm/min | mm/min | mm | mm | mm | mm | mm | mm | mm | mm | | kg |
| 154/MR | 10 | 1750 | 350 | 1910 | 500 | 1100 | 520 | 980 | 120 | 260 | 40 | 0,75 kw | 194 |
| 156/MR | 20 | 1100 | 300 | 1960 | 500 | 1110 | 510 | 1000 | 140 | 285 | 50 | 0,75 kw | 208 |
| P30/MR | 30 | 1550 | 300 | 2020 | 600 | 1600 | 695 | 1000 | 170 | 260 | 60 | 1,5 kw | 338 |
| 161/R* | 40 | 1530 | 300 | 2130 | 850 | 1650 | 775 | 1135 | 195 | 260 | 60 | 1,5 kw | 530 |
| 162/R | 50 | 1540 | 210 | 2130 | 850 | 1650 | 775 | 1135 | 205 | 260 | 60 | 1,5 kw | 560 |
| 163/R | 70 | 1600 | 260 | 2210 | 900 | 1755 | 880 | 1120 | 265 | 310 | 90 | 3 kw | 850 |
| 164/R | 100 | 1600 | 180 | 2310 | 900 | 1930 | 1010 | 1055 | 280 | 310 | 110 | 3 kw | 1100 |

(*) Salvo esaurimento scorte

001 - ø 100 mm

~~€ 78,50~~ - **€ 46,00**

PER ART. 153 • 154/E • 154 • 155 • 156 •
154/P • 155/P • 156/P

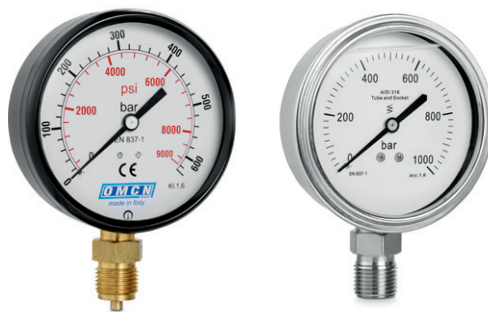

MANOMETRO

002 - ø 63 mm

~~€ 138,00~~ - **€ 81,00**

PER ART. 152

002/A - ø 100 mm

~~€ 201,00~~ - **€ 118,00**

PER ART. 154/IP • 155/IP • 156/IP

010 - Portata 10 Ton.

~~€ 72,00~~ - **€ 43,00**

011 - Portata 15-20 Ton.

~~€ 82,50~~ - **€ 49,00**

011/A - Portata 30 Ton.

~~€ 263,00~~ - **€ 154,00**

012 - Portata 40-50 Ton.

~~€ 287,00~~ - **€ 169,00**

PIATTO CACCIASPINE



012/A - Portata 50 Ton.

~~€ 432,00~~ - **€ 256,00**

013 - Portata 70 Ton.

~~€ 432,00~~ - **€ 256,00**

014 - Portata 100 Ton.

~~€ 527,00~~ - **€ 312,00**

014/A - Portata 100 Ton.

~~€ 808,00~~ - **€ 478,00**

| ART. | Compatibilità | A mm | B mm | Diametro | KG |
|-------|---|------|------|-----------------|----|
| 010 | SERIE 10 TON | 200 | 200 | 22 mm | 5 |
| 011 | SERIE 15 - 20 TON | 200 | 200 | 22 mm | 5 |
| 011/A | SERIE 30 TON | 240 | 400 | 15 - 22 - 28 mm | 23 |
| 012 | SERIE 40 - 50 TON | 300 | 400 | 15 - 22 - 28 mm | 28 |
| 012/A | SERIE 50 TON + ART. 022 | 400 | 400 | 15 - 22 - 28 mm | 50 |
| 013 | SERIE 70 TON | 400 | 400 | 15 - 22 - 28 mm | 50 |
| 014 | SERIE 100 TON (D = 1000 mm) | 400 | 400 | 15 - 22 - 28 mm | 63 |
| 014/A | SERIE 100 TON + ART. 022/A SERIE 100 TON (D = 1500 mm) | 480 | 480 | 20 - 30 - 40 mm | 90 |

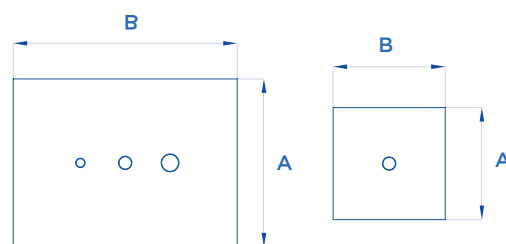

D = Luce pressa

SET DI 8 PERNI CACCIASPINE

045

~~€ 492,00~~ - **€ 291,00**

PER SERIE 10 - 15 - 20 - 30 TON

| A mm | B mm | Forza di spinta massima |
|------|------|-------------------------|
| 12 | 65 | 0,8 TON |
| 14 | 65 | 1 TON |
| 16 | 65 | 1,5 TON |
| 18 | 65 | 2 TON |
| 20 | 65 | 2,5 TON |
| 22 | 65 | 3 TON |
| 25 | 65 | 3,8 TON |
| 30 | 65 | 5 TON |

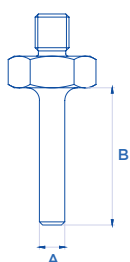

CILINDRO MOBILE

020

~~€ 137,00~~ - € 81,00

PER ART. 154 • 155 • 156

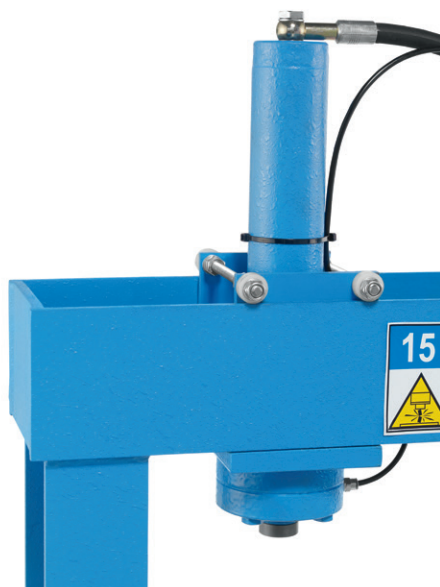

021

~~€ 314,00~~ - € 186,00

PER ART. P30/SA

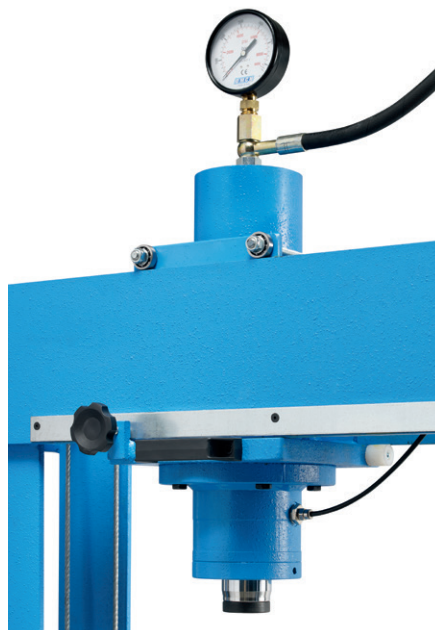

022

~~€ 3.098,00~~ - € 1.832,00

PER ART. 162/W • 162/R

022/A

~~€ 3.913,00~~ - € 2.314,00

PER ART. 164/W • 164/R



030 - Portata 10 Ton.

~~€ 125,00~~ - € 74,00

031 - Portata 15-20 Ton.

~~€ 154,50~~ - € 91,00

031/A - Portata 30 Ton.

~~€ 377,00~~ - € 221,00

031/B - Portata 40 Ton.

~~€ 377,00~~ - € 221,00

PRISMI A V

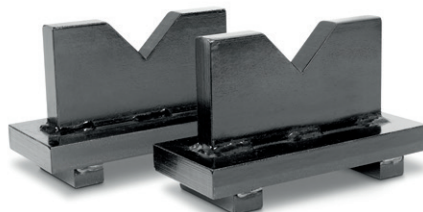

032 - Portata 50 Ton.

~~€ 377,00~~ - € 221,00

032/A - Portata 50 Ton.

~~€ 490,00~~ - € 288,00

033 - Portata 70 Ton.

~~€ 490,00~~ - € 288,00

034 - Portata 100 Ton.

~~€ 562,00~~ - € 332,00

034/A - Portata 100 Ton.

~~€ 840,00~~ - € 497,00

| ART. | Compatibilità | A mm | B mm | C mm | D mm | E mm | F mm | G mm | KG |
|-------|---|------|------|------|------|------|------|------|----|
| 030 | SERIE 10 TON | 160 | 70 | 95 | 170 | 80 | 15 | 120 | 4 |
| 031 | SERIE 15 - 20 TON | 160 | 70 | 95 | 190 | 80 | 15 | 120 | 8 |
| 031/A | SERIE 30 TON | 190 | 80 | 125 | 240 | 100 | 25 | 100 | 9 |
| 031/B | SERIE 40 TON | 250 | 100 | 145 | 300 | 120 | 25 | 100 | 12 |
| 032 | SERIE 50 TON | 250 | 100 | 145 | 320 | 120 | 25 | 100 | 13 |
| 032/A | SERIE 50 TON + ART. 022 | 330 | 100 | 180 | 380 | 150 | 30 | 100 | 20 |
| 033 | SERIE 70 TON | 330 | 100 | 180 | 380 | 150 | 30 | 100 | 20 |
| 034 | SERIE 100 TON (D = 1000 mm) | 330 | 100 | 180 | 410 | 150 | 30 | 100 | 20 |
| 034/A | SERIE 100 TON + ART. 022/A SERIE 100 TON (D = 1500 mm) | 330 | 100 | 190 | 480 | 150 | 30 | 120 | 32 |

D = Luce pressa

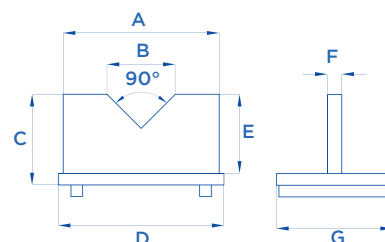

041
~~€ 215,00~~ - € 128,00

043
~~€ 159,00~~ - € 94,00

044
~~€ 160,00~~ - € 95,00

041/A
~~€ 399,00~~ - € 236,00

043/A
~~€ 282,00~~ - € 167,00

044/A
~~€ 318,00~~ - € 188,00

042
~~€ 211,00~~ - € 125,00

042/A
~~€ 482,00~~ - € 285,00

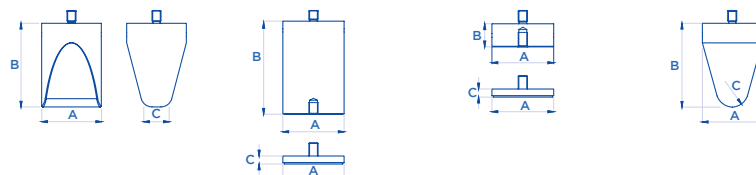

| ART. | Compatibilità | A mm | B mm | C mm |
|--------------|------------------------|------|------|------|
| 041 | SERIE 30 - 40 - 50 TON | 57 | 100 | 25 |
| 041/A | SERIE 70 - 100 TON | 107 | 150 | 45 |
| 042 | SERIE 30 - 40 - 50 TON | 57 | 150 | 14 |
| 042/A | SERIE 70 - 100 TON | 107 | 200 | 14 |
| 043 | SERIE 30 - 40 - 50 TON | 57 | 40 | 14 |
| 043/A | SERIE 70 - 100 TON | 107 | 40 | 14 |
| 044 | SERIE 30 - 40 - 50 TON | 57 | 100 | 20 |
| 044/A | SERIE 70 - 100 TON | 107 | 150 | 30 |



ART. 041 • 041/A



ART. 042 • 042/A



ART. 043 • 043/A



ART. 044 • 044/A

PIASTRA FRESATA CON CAVE A T

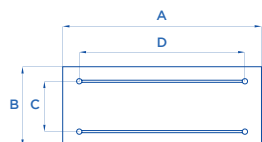

D = Luce pressa

| ART. | Compatibilità | A mm | B mm | C mm | D mm | KG |
|------------|-----------------------------|------|------|------|------|-----|
| 080 | SERIE 40 - 50 TON | 750 | 400 | 160 | 600 | 100 |
| 081 | SERIE 70 TON | 850 | 450 | 270 | 700 | 170 |
| 082 | SERIE 100 TON (D = 1000 mm) | 990 | 500 | 300 | 800 | 220 |

080
~~€ 2.833,00~~ - € 1.674,00

081
~~€ 3.278,00~~ - € 1.937,00

082
~~€ 3.726,00~~ - € 2.202,00

PANNELLO DI PROTEZIONE FRONTALE



090
~~€ 567,00~~ - € 335,00

| ART. | Compatibilità |
|--------------|-----------------------------|
| 090 | SERIE 10 - 15 - 20 TON |
| 090/A | SERIE 30 TON |
| 090/B | SERIE 40 - 50 TON |
| 090/C | SERIE 70 TON |
| 090/D | SERIE 100 TON (D = 1000 mm) |

D = Luce pressa

090/A
~~€ 605,00~~ - € 358,00

090/B
~~€ 644,00~~ - € 381,00

090/C
~~€ 694,00~~ - € 410,00

090/D
~~€ 750,00~~ - € 444,00



PRESSA ELETTRIDRAULICA SCHIACCIA FILTRI

389/A

~~€ 8.839,00~~ - € 5.290,00

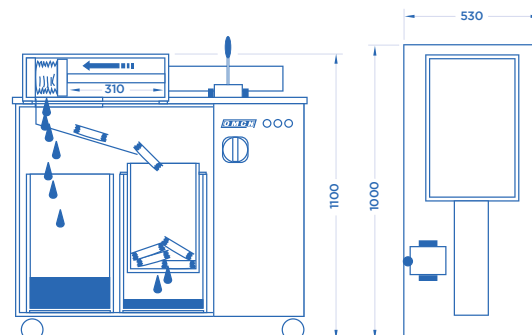

| ART. | TON | Dimensioni camera | KG |
|-------|-----|--------------------|-----|
| 389/A | 40 | 175 x 260 x 320 mm | 250 |

PRESSE IDRAULICHE SCHIACCIA BARATTOLI

390/A

~~€ 5.733,00~~ - € 3.429,00

Pressa completa di pompa elettroidraulica.



390/B

~~€ 5.098,00~~ - € 2.990,00

Pressa completa di pompa idropneumatica.





396

~~€ 5.969~~ - € 3.550,00

Indicata per carta e cartone, a funzionamento pneumatico è dotata di doppio bloccaggio di sicurezza e di pianale inferiore parzialmente estraibile per una più facile evacuazione della palla formata.

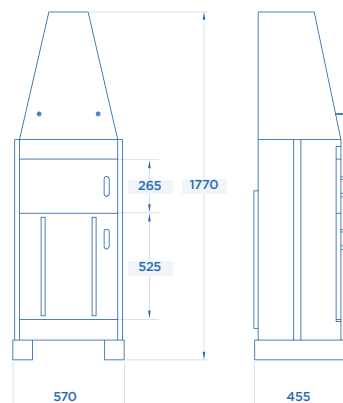

| ART. | KG | Corsa pistone | | | | | |
|------|-----|---------------|--------|-----|-----|-----|-----|
| 396 | 700 | 500 mm | 10 bar | 500 | 780 | 400 | 150 |



215 - Portata 15000 kg

~~€ 639,00~~ - € 379,00

216 - Portata 15000 kg

~~€ 751,00~~ - € 445,00

HEAVY DUTY

| ART. | | MAX mm | MIN mm | KG |
|------|----------|--------|--------|----|
| 215 | 15000 kg | 680 | 470 | 27 |
| 216 | 15000 kg | 1170 | 680 | 36 |



217 - Portata 20000 kg

~~€ 455,00~~ - € 269,00

218 - Portata 20000 kg

~~€ 564,00~~ - € 334,00

HEAVY DUTY

| ART. | | MAX mm | MIN mm | KG |
|------|----------|--------|--------|----|
| 217 | 20000 kg | 640 | 410 | 29 |
| 218 | 20000 kg | 1080 | 670 | 32 |



110 - Portata 1000 kg

~~€ 50,50~~ - € 30,00

110/A - Portata 1000 kg

~~€ 59,50~~ - € 35,00

110/B - Portata 3500 kg

~~€ 111,00~~ - € 65,00

110/C - Portata 3500 kg

~~€ 158,00~~ - € 93,00

151 - Portata 1000 kg

~~€ 240,00~~ - € 142,00

| ART. | | MAX mm | MIN mm | KG |
|-------|---------|--------|--------|----|
| 110 | 1000 kg | 480 | 280 | 3 |
| 110/A | 1000 kg | 650 | 380 | 4 |
| 110/B | 3500 kg | 740 | 440 | 8 |
| 110/C | 3500 kg | 1170 | 700 | 11 |
| 151 | 1000 kg | 1885 | 1120 | 17 |

COLONNETTE DI SOSTEGNO

24 MESI
Garanzia

OMCN
S.p.A.

MADE IN ITALY

HEAVY DUTY



239 - Portata 8000 kg

~~€ 286,00~~ - € 169,00

239/A - Portata 5000 kg

~~€ 241,00~~ - € 143,00

240 - Portata 12000 kg

~~€ 344,00~~ - € 203,00

241 - Portata 8000 kg

~~€ 335,00~~ - € 198,00

241/A - Portata 5000 kg

~~€ 292,00~~ - € 173,00

242 - Portata 12000 kg

~~€ 403,00~~ - € 238,00

| ART. | | MAX mm | MIN mm | KG | ART. | | MAX mm | MIN mm | KG |
|--------------|----------|--------|--------|----|--------------|----------|--------|--------|----|
| 239 | 8000 kg | 740 | 450 | 18 | 241 | 8000 kg | 1100 | 650 | 23 |
| 239/A | 5000 kg | 740 | 450 | 13 | 241/A | 5000 kg | 1100 | 650 | 16 |
| 240 | 12000 kg | 740 | 450 | 25 | 242 | 12000 kg | 1100 | 650 | 31 |



Sollevatore composto da pompa idropneumatica e due colonnette idrauliche, portata 10 ton ciascuna, con funzionamento in coppia o indipendente una dall'altra. Colonnelle dotate inoltre di sistema manuale di variazione dell'altezza minima. La soluzione ideale per il sollevamento libera ruote dei veicoli pesanti e per un rapido intervento sugli stessi.

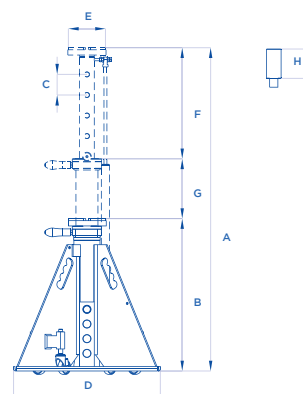

930 - Portata 10000x2 kg

~~€ 5.869,00~~ - € 3.490,00

| ART. | | A mm | B mm | C mm | D mm | E mm | F mm | G mm | H mm |
|------------|-------------|------|------|------|------|------|------|------|------|
| 930 | 10000 Kg x2 | 1120 | 555 | 70 | 500 | 130 | 330 | 215 | 100 |

982 - Portata 10000 kg

~~€ 1.323,00~~ - € 789,00

982/B - Portata 7200 kg

~~€ 1.041,00~~ - € 625,00

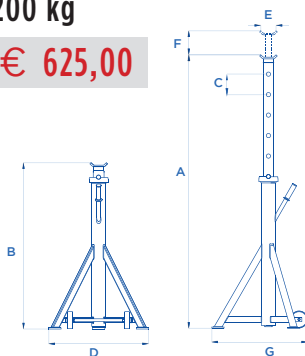

982/A - Portata 10000 kg

~~€ 1.620,00~~ - € 969,00

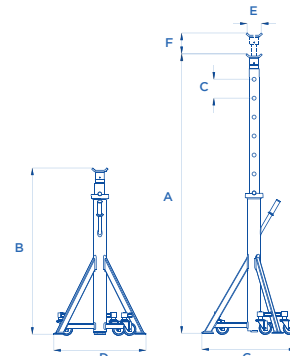

| ART. | | A mm | B mm | C mm | D mm | E mm | F mm | G mm | ART. | | A mm | B mm | C mm | D mm | E mm | F mm | G mm |
|--------------|----------|------|------|------|------|------|------|------|--------------|----------|------|------|------|------|------|------|------|
| 982 | 10000 Kg | 2050 | 1300 | 150 | 730 | 130 | 70 | 700 | 982/A | 10000 Kg | 2050 | 1300 | 150 | 730 | 130 | 70 | 660 |
| 982/B | 7200 Kg | 2050 | 1300 | 150 | 715 | 130 | 700 | | | | | | | | | | |



111 - Portata 300 kg

~~€ 313,00~~ - € 185,00

- Cavalletto per la revisione dei motori.
- Permette una rotazione di 360° del motore.
- Robusta struttura rinforzata in acciaio saldato.
- Fermo meccanico a vite per bloccare il motore in posizione.
- Braccetti di ancoraggio zincati a regolazione multipla per garantire una compatibilità assoluta.
- Vaschetta porta oggetti di serie.

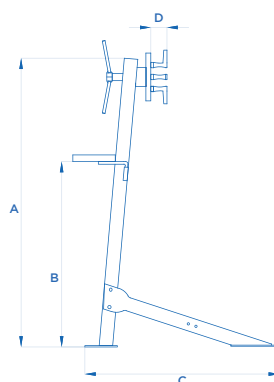

| | | | | | | |
|------|--------|------------------------|------------------------|------------------------|------------------------|----|
| ART. | | A \leftrightarrow mm | B \leftrightarrow mm | C \leftrightarrow mm | D \leftrightarrow mm | |
| 111 | 300 kg | 1100 | 710 | 570 | 60 | 28 |



219 - Portata 450 kg

~~€ 693,00~~ - € 410,00

- Cavalletto doppio per la revisione dei motori.
- Permette una rotazione di 360° del motore.
- Dotato di quattro ruote girevoli con possibilità di bloccaggio.
- Fermo meccanico a vite per bloccare il motore in posizione.
- Braccetti di ancoraggio zincati a regolazione multipla per garantire una compatibilità assoluta.
- Regolabile in lunghezza.
- Vasca di recupero contro la perdita di liquidi di serie.

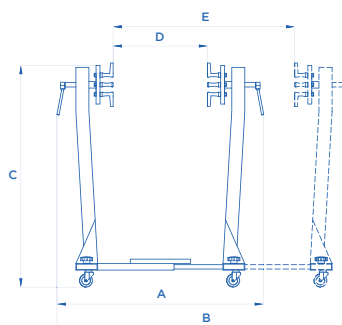

| | | | | | | | |
|------|--------|------------------------|------------------------|------------------------|------------------------|------------------------|----|
| ART. | | A \leftrightarrow mm | B \leftrightarrow mm | C \leftrightarrow mm | D \leftrightarrow mm | E \leftrightarrow mm | |
| 219 | 450 kg | 755 | 1120 | 930 | 320 | 685 | 50 |

SOLLEVATORI IDRAULICI A BOTTIGLIA

24 MESI
GARANZIA

OMCN
S.p.A.

MADE IN ITALY

- Dodici modelli con portate da 3 a 50 ton.
- Struttura sovradimensionata in acciaio ad alta resistenza; la più solida sul mercato.
- Base d'appoggio di grandi dimensioni a garanzia della massima stabilità.
- Valvola di protezione contro i sovraccarichi incorporata.
- I modelli più pesanti sono dotati di maniglia per agevolare il trasporto.
- Avvicinamento al punto di sollevamento rapido e preciso grazie alla vite incorporata (escluso art. 125 - 125/A - 130/A).

125 - Portata 3000 kg

~~€ 115,00~~ - € 68,00

125/A - Portata 3000 kg

~~€ 119,00~~ - € 70,00

126 - Portata 5000 kg

~~€ 139,00~~ - € 82,00

126/A - Portata 5000 kg

~~€ 132,00~~ - € 78,00

126/B - Portata 5000 kg

~~€ 183,00~~ - € 109,00

127 - Portata 10000 kg

~~€ 177,00~~ - € 105,00

127/A - Portata 10000 kg

~~€ 231,00~~ - € 138,00

128 - Portata 15000 kg

~~€ 231,00~~ - € 137,00

129 - Portata 20000 kg

~~€ 321,00~~ - € 190,00

129/A - Portata 25000 kg

~~€ 398,00~~ - € 236,00

130 - Portata 30000 kg

~~€ 462,00~~ - € 273,00

130/A - Portata 50000 kg

~~€ 1.241,00~~ - € 735,00

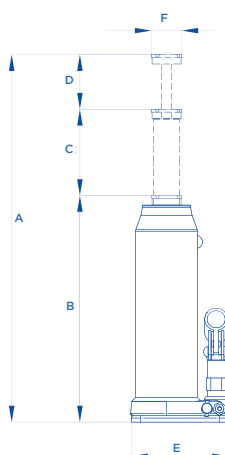

130/B - Portata 5000 kg

~~€ 746,00~~ - € 442,00

BINDE IDRAULICHE



| ART. | | A mm | B mm | C mm | D mm | E mm | F mm | KG |
|-------|----------|------|------|------|------|---------|------|-----|
| 125 | 3000 kg | 325 | 200 | 125 | | 120x120 | 40 | 4,8 |
| 125/A | 3000 kg | 400 | 240 | 160 | | 120x120 | 40 | 5,2 |
| 126 | 5000 kg | 485 | 220 | 140 | 125 | 120x120 | 40 | 5,5 |
| 126/A | 5000 kg | 370 | 190 | 105 | 75 | 120x120 | 40 | 5 |
| 126/B | 5000 kg | 630 | 275 | 195 | 160 | 120x120 | 40 | 6,5 |
| 127 | 10000 kg | 515 | 240 | 150 | 125 | 140x140 | 50 | 8 |
| 127/A | 10000 kg | 710 | 310 | 225 | 175 | 140x140 | 50 | 9,8 |
| 128 | 15000 kg | 515 | 245 | 150 | 120 | 140x140 | 60 | 10 |
| 129 | 20000 kg | 575 | 285 | 165 | 125 | 170x170 | 60 | 18 |
| 129/A | 25000 kg | 575 | 285 | 165 | 125 | 170x170 | 60 | 19 |
| 130 | 30000 kg | 585 | 295 | 165 | 125 | 225x183 | 65 | 25 |
| 130/A | 50000 kg | 430 | 270 | 160 | | 280x230 | 90 | 53 |

| ART. | | MAX mm | MIN mm |
|-------|---------|--------|--------|
| 130/B | 5000 kg | 170 | 30 |



INGOMBRO RIDOTTO

| ART. | TON | Pressione | Capacità olio | A mm | B mm | C mm | D mm | KG | ART. Pompa Manuale | | ART. Pompa Idropneumatica |
|--------------|-----|-----------|-----------------------|------|------|------|------|-----|--------------------|------------|---------------------------|
| | | | | | | | | | 1 Velocità | 2 Velocità | |
| 359 | 5 | 700 bar | 15,3 cm ³ | 76 | 60 | 16 | 30 | 0,6 | 358/A | 358/D | 357 |
| 359/A | 5 | 700 bar | 33,6 cm ³ | 115 | 80 | 35 | 30 | 0,8 | 358/A | 358/D | 357 |
| 360 | 10 | 700 bar | 25,4 cm ³ | 76 | 60 | 16 | 40 | 0,9 | 358/A | 358/C | 357 |
| 360/A | 10 | 700 bar | 55,6 cm ³ | 115 | 80 | 35 | 40 | 1,2 | 358/A | 358/C | 357 |
| 361 | 20 | 700 bar | 26,4 cm ³ | 78 | 70 | 8 | 60 | 2,7 | 358/A | 358/C | 357 |
| 361/A | 20 | 700 bar | 66,2 cm ³ | 105 | 85 | 20 | 60 | 3,3 | 358/A | 358/C | 357 |
| 362 | 30 | 700 bar | 40,1 cm ³ | 78 | 70 | 8 | 75 | 3,8 | 358/A | 358/C | 357 |
| 362/A | 30 | 700 bar | 100,4 cm ³ | 105 | 85 | 20 | 75 | 4,5 | 358/A | 358/C | 357 |
| 363 | 50 | 700 bar | 39,2 cm ³ | 75 | 70 | 5 | 90 | 6 | 358/A | 358/C | 357 |
| 363/A | 50 | 700 bar | 117,7 cm ³ | 100 | 85 | 15 | 90 | 7,1 | 358/A | 358/C | 357 |

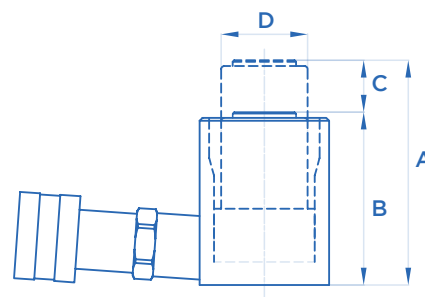
359 - Portata 5 Ton.
~~€ 223,00~~ - € 133,00

359/A - Portata 5 Ton.
~~€ 243,00~~ - € 145,00

360 - Portata 10 Ton.
~~€ 289,00~~ - € 171,00

360/A - Portata 10 Ton.
~~€ 303,00~~ - € 179,00

361 - Portata 20 Ton.
~~€ 508,00~~ - € 300,00

361/A - Portata 20 Ton.
~~€ 530,00~~ - € 313,00

362 - Portata 30 Ton.
~~€ 620,00~~ - € 366,00

362/A - Portata 30 Ton.
~~€ 634,00~~ - € 374,00

363 - Portata 50 Ton.
~~€ 823,00~~ - € 485,00

363/A - Portata 50 Ton.
~~€ 835,00~~ - € 493,00



INGOMBRO RIDOTTO

| ART. | TON | Pressione | Capacità olio | A mm | B mm | C mm | D mm | KG | ART. Pompa Manuale | | ART. Pompa Idropneumatica |
|---------------|-----|-----------|-----------------------|------|------|------|------|-----|--------------------|------------|---------------------------|
| | | | | | | | | | 1 Velocità | 2 Velocità | |
| 359/M | 5 | 700 bar | 15,3 cm ³ | 76 | 60 | 16 | 30 | 0,6 | 358/A | 358/D | 357 |
| 359/AM | 5 | 700 bar | 33,6 cm ³ | 115 | 80 | 35 | 30 | 0,8 | 358/A | 358/D | 357 |
| 360/M | 10 | 700 bar | 25,4 cm ³ | 76 | 60 | 16 | 40 | 0,9 | 358/A | 358/C | 357 |
| 360/AM | 10 | 700 bar | 55,6 cm ³ | 115 | 80 | 35 | 40 | 1,2 | 358/A | 358/C | 357 |
| 361/M | 20 | 700 bar | 26,4 cm ³ | 78 | 70 | 8 | 60 | 2,7 | 358/A | 358/C | 357 |
| 361/AM | 20 | 700 bar | 66,2 cm ³ | 105 | 85 | 20 | 60 | 3,3 | 358/A | 358/C | 357 |
| 362/M | 30 | 700 bar | 40,1 cm ³ | 78 | 70 | 8 | 75 | 3,8 | 358/A | 358/C | 357 |
| 362/AM | 30 | 700 bar | 100,4 cm ³ | 105 | 85 | 20 | 75 | 4,5 | 358/A | 358/C | 357 |
| 363/M | 50 | 700 bar | 39,2 cm ³ | 75 | 70 | 5 | 90 | 6 | 358/A | 358/C | 357 |
| 363/AM | 50 | 700 bar | 117,7 cm ³ | 100 | 85 | 15 | 90 | 7,1 | 358/A | 358/C | 357 |

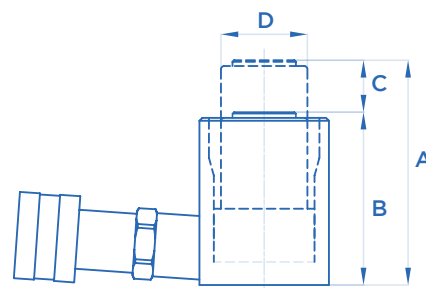

359/M - Portata 5 Ton.

~~€ 268,00~~ - € 159,00

359/AM - Portata 5 Ton.

~~€ 292,00~~ - € 172,00

360/M - Portata 10 Ton.

~~€ 345,00~~ - € 203,00

360/AM - Portata 10 Ton.

~~€ 366,00~~ - € 216,00

361/M - Portata 20 Ton.

~~€ 609,00~~ - € 359,00

361/AM - Portata 20 Ton.

~~€ 637,00~~ - € 376,00

362/M - Portata 30 Ton.

~~€ 745,00~~ - € 439,00

362/AM - Portata 30 Ton.

~~€ 762,00~~ - € 450,00

363/M - Portata 50 Ton.

~~€ 990,00~~ - € 584,00

363/AM - Portata 50 Ton.

~~€ 1.004,00~~ - € 592,00



IMPIEGHI GENERICI

| ART. | TON | Pressione | Capacità olio | A mm | B mm | C mm | D mm | KG | ART. Pompa Manuale | | ART. Pompa Idropneumatica |
|-------|-----|-----------|-----------------------|------|------|------|------|------|--------------------|------------|---------------------------|
| | | | | | | | | | 1 Velocità | 2 Velocità | |
| 359/B | 5 | 700 bar | 52,8 cm ³ | 155 | 100 | 55 | 30 | 1 | 358/A | 358/D | 357 |
| 359/C | 5 | 700 bar | 72 cm ³ | 195 | 120 | 75 | 30 | 1,2 | 358/A | 358/D | 357 |
| 359/D | 5 | 700 bar | 100,8 cm ³ | 255 | 150 | 105 | 30 | 1,5 | 358/A | 358/D | 357 |
| 360/B | 10 | 700 bar | 87,4 cm ³ | 155 | 100 | 55 | 40 | 1,6 | 358/A | 358/C | 357 |
| 360/C | 10 | 700 bar | 119,2 cm ³ | 195 | 120 | 75 | 40 | 1,9 | 358/A | 358/C | 357 |
| 360/D | 10 | 700 bar | 167 cm ³ | 255 | 150 | 105 | 40 | 2,4 | 358/A | 358/C | 357 |
| 361/B | 20 | 700 bar | 132,4 cm ³ | 145 | 105 | 40 | 60 | 4,1 | 358/A | 358/C | 357 |
| 361/C | 20 | 700 bar | 198,6 cm ³ | 185 | 125 | 60 | 60 | 4,9 | 358/A | 358/C | 357 |
| 361/D | 20 | 700 bar | 331 cm ³ | 265 | 165 | 100 | 60 | 6,5 | 358/A | 358/C | 357 |
| 362/B | 30 | 700 bar | 200,8 cm ³ | 145 | 105 | 40 | 75 | 5,6 | 358/A | 358/C | 357 |
| 362/C | 30 | 700 bar | 301,2 cm ³ | 185 | 125 | 60 | 75 | 6,8 | 358/A | 358/C | 357 |
| 362/D | 30 | 700 bar | 502 cm ³ | 265 | 165 | 100 | 75 | 9,2 | 358/A | 358/C | 357 |
| 363/B | 50 | 700 bar | 274,7 cm ³ | 140 | 105 | 35 | 90 | 9,2 | 358/A | 358/C | 357 |
| 363/C | 50 | 700 bar | 431,7 cm ³ | 180 | 125 | 55 | 90 | 11 | 358/A | 358/C | 357 |
| 363/D | 50 | 700 bar | 745,7 cm ³ | 260 | 165 | 95 | 90 | 15,2 | 358/A | 358/C | 357 |

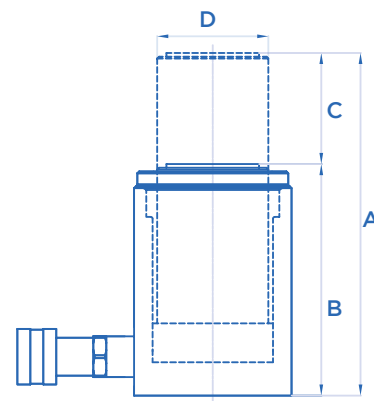

359/B - Portata 5 Ton.
~~€ 252,00~~ - € 149,00

359/C - Portata 5 Ton.
~~€ 267,00~~ - € 158,00

359/D - Portata 5 Ton.
~~€ 283,00~~ - € 168,00

360/B - Portata 10 Ton.
~~€ 310,00~~ - € 184,00

360/C - Portata 10 Ton.
~~€ 328,00~~ - € 194,00

360/D - Portata 10 Ton.
~~€ 334,00~~ - € 198,00

361/B - Portata 20 Ton.
~~€ 544,00~~ - € 320,00

361/C - Portata 20 Ton.
~~€ 567,00~~ - € 333,00

361/D - Portata 20 Ton.
~~€ 598,00~~ - € 351,00

362/B - Portata 30 Ton.
~~€ 650,00~~ - € 385,00

362/C - Portata 30 Ton.
~~€ 665,00~~ - € 394,00

362/D - Portata 30 Ton.
~~€ 687,00~~ - € 407,00

363/B - Portata 50 Ton.
~~€ 847,00~~ - € 517,00

363/C - Portata 50 Ton.
~~€ 890,00~~ - € 527,00

363/D - Portata 50 Ton.
~~€ 921,00~~ - € 545,00



IMPIEGHI GENERICI

| ART. | TON | Pressione | Capacità olio | A mm | B mm | C mm | D mm | KG | ART. Pompa Manuale | | ART. Pompa Idropneumatica |
|--------|-----|-----------|-----------------------|------|------|------|------|------|--------------------|------------|---------------------------|
| | | | | | | | | | 1 Velocità | 2 Velocità | |
| 359/BM | 5 | 700 bar | 52,8 cm ³ | 155 | 100 | 55 | 30 | 1 | 358/A | 358/D | 357 |
| 359/CM | 5 | 700 bar | 72 cm ³ | 195 | 120 | 75 | 30 | 1,2 | 358/A | 358/D | 357 |
| 359/DM | 5 | 700 bar | 100,8 cm ³ | 255 | 150 | 105 | 30 | 1,5 | 358/A | 358/D | 357 |
| 360/BM | 10 | 700 bar | 87,4 cm ³ | 155 | 100 | 55 | 40 | 1,6 | 358/A | 358/C | 357 |
| 360/CM | 10 | 700 bar | 119,2 cm ³ | 195 | 120 | 75 | 40 | 1,9 | 358/A | 358/C | 357 |
| 360/DM | 10 | 700 bar | 167 cm ³ | 255 | 150 | 105 | 40 | 2,4 | 358/A | 358/C | 357 |
| 361/BM | 20 | 700 bar | 132,4 cm ³ | 145 | 105 | 40 | 60 | 4,1 | 358/A | 358/C | 357 |
| 361/CM | 20 | 700 bar | 198,6 cm ³ | 185 | 125 | 60 | 60 | 4,9 | 358/A | 358/C | 357 |
| 361/DM | 20 | 700 bar | 331 cm ³ | 265 | 165 | 100 | 60 | 6,5 | 358/A | 358/C | 357 |
| 362/BM | 30 | 700 bar | 200,8 cm ³ | 145 | 105 | 40 | 75 | 5,6 | 358/A | 358/C | 357 |
| 362/CM | 30 | 700 bar | 301,2 cm ³ | 185 | 125 | 60 | 75 | 6,8 | 358/A | 358/C | 357 |
| 362/DM | 30 | 700 bar | 502 cm ³ | 265 | 165 | 100 | 75 | 9,2 | 358/A | 358/C | 357 |
| 363/BM | 50 | 700 bar | 274,7 cm ³ | 140 | 105 | 35 | 90 | 9,2 | 358/A | 358/C | 357 |
| 363/CM | 50 | 700 bar | 431,7 cm ³ | 180 | 125 | 55 | 90 | 11 | 358/A | 358/C | 357 |
| 363/DM | 50 | 700 bar | 745,7 cm ³ | 260 | 165 | 95 | 90 | 15,2 | 358/A | 358/C | 357 |

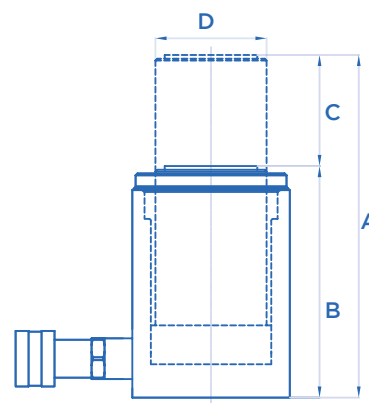

359/BM - Portata 5 Ton.

~~€ 302,00~~ - € 179,00

359/CM - Portata 5 Ton.

~~€ 320,00~~ - € 189,00

359/DM - Portata 5 Ton.

~~€ 337,00~~ - € 199,00

360/BM - Portata 10 Ton.

~~€ 375,00~~ - € 222,00

360/CM - Portata 10 Ton.

~~€ 393,00~~ - € 232,00

360/DM - Portata 10 Ton.

~~€ 400,00~~ - € 235,00

361/BM - Portata 20 Ton.

~~€ 654,00~~ - € 384,00

361/CM - Portata 20 Ton.

~~€ 680,00~~ - € 399,00

361/DM - Portata 20 Ton.

~~€ 718,00~~ - € 425,00

362/BM - Portata 30 Ton.

~~€ 779,00~~ - € 461,00

362/CM - Portata 30 Ton.

~~€ 798,00~~ - € 472,00

362/DM - Portata 30 Ton.

~~€ 825,00~~ - € 488,00

363/BM - Portata 50 Ton.

~~€ 1.050,00~~ - € 622,00

363/CM - Portata 50 Ton.

~~€ 1.066,00~~ - € 631,00

363/DM - Portata 50 Ton.

~~€ 1.104,00~~ - € 653,00



ALTA POTENZA

| ART. | TON | Pressione | Capacità olio | A mm | B mm | C mm | D mm | KG | ART. Pompa Manuale | | ART. Pompa Idropneumatica |
|---------------|-----|-----------|----------------------|------|------|------|------|------|--------------------|------------|---------------------------|
| | | | | | | | | | 1 Velocità | 2 Velocità | |
| 364/M | 85 | 520 bar | 794 cm ³ | 245 | 200 | 45 | 110 | 32,5 | | 358/D | 357/A |
| 364/AM | 85 | 520 bar | 1677 cm ³ | 345 | 250 | 95 | 110 | 38,6 | | 358/D | 357/A |
| 364/BM | 85 | 520 bar | 3090 cm ³ | 505 | 330 | 175 | 110 | 48,5 | | 358/D | 357/A |
| 365/M | 125 | 520 bar | 1144 cm ³ | 265 | 220 | 45 | 140 | 48,5 | | 358/D | 357/A |
| 365/AM | 125 | 520 bar | 2416 cm ³ | 365 | 270 | 95 | 140 | 59,5 | | 358/D | 357/A |
| 365/BM | 125 | 520 bar | 4450 cm ³ | 525 | 350 | 175 | 140 | 77 | | 358/E | 357/B |
| 368/M | 190 | 520 bar | 1709 cm ³ | 295 | 250 | 45 | 170 | 91,5 | | 358/D | 357/A |
| 368/AM | 190 | 520 bar | 3609 cm ³ | 395 | 300 | 95 | 170 | 110 | | 358/D | 357/A |
| 368/BM | 190 | 520 bar | 6648 cm ³ | 555 | 380 | 175 | 170 | 140 | | 358/E | 357/B |
| 368/CM | 245 | 520 bar | 2207 cm ³ | 305 | 260 | 45 | 210 | 121 | | 358/D | 357/A |
| 368/DM | 245 | 520 bar | 6623 cm ³ | 485 | 350 | 135 | 210 | 163 | | 358/E | 357/B |

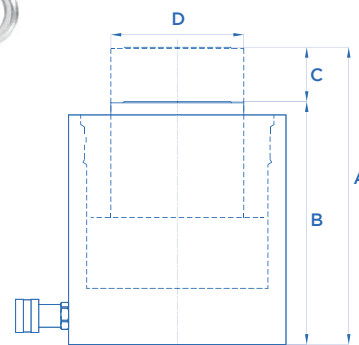

364/M - Portata 85 Ton.

~~€ 1.858,00~~ - € 1.102,00

365/AM - Portata 125 Ton.

~~€ 2.979,00~~ - € 1.766,00

368/BM - Portata 190 Ton.

~~€ 5.643,00~~ - € 3.345,00

364/AM - Portata 85 Ton.

~~€ 2.036,00~~ - € 1.207,00

365/BM - Portata 125 Ton.

~~€ 3.331,00~~ - € 1.975,00

368/CM - Portata 245 Ton.

~~€ 6.846,00~~ - € 4.058,00

364/BM - Portata 85 Ton.

~~€ 2.257,00~~ - € 1.338,00

368/M - Portata 190 Ton.

~~€ 4.593,00~~ - € 2.722,00

368/DM - Portata 245 Ton.

~~€ 7.747,00~~ - € 4.592,00

365/M - Portata 125 Ton.

~~€ 2.703,00~~ - € 1.602,00

368/AM - Portata 190 Ton.

~~€ 5.045,00~~ - € 2.990,00



CORSA LUNGA

| ART. | TON | Pressione | Capacità olio | A mm | B mm | C mm | D mm | E mm | F mm | G mm | H mm | I mm | L mm | M mm | KG |
|--------|-----|-----------|------------------------|------|------|------|------|------|------|-------|------|---------|------|------|------|
| 359/EM | 5 | 700 bar | 120 cm ³ | 370 | 245 | 125 | 30 | 20 | 25 | M50X2 | 12 | M16X2 | 32 | M8 | 2,5 |
| 359/FM | 5 | 700 bar | 144 cm ³ | 420 | 270 | 150 | 30 | 20 | 25 | M50X2 | 12 | M16X2 | 32 | M8 | 2,7 |
| 359/GM | 5 | 700 bar | 178 cm ³ | 470 | 295 | 175 | 30 | 20 | 25 | M50X2 | 12 | M16X2 | 32 | M8 | 2,9 |
| 359/HM | 5 | 700 bar | 240 cm ³ | 620 | 370 | 250 | 30 | 20 | 25 | M50X2 | 12 | M16X2 | 32 | M8 | 3,5 |
| 360/EM | 10 | 700 bar | 222 cm ³ | 405 | 265 | 140 | 40 | 20 | 30 | M64X2 | 25 | M24X3 | 45 | M8 | 5,2 |
| 360/FM | 10 | 700 bar | 333 cm ³ | 545 | 335 | 210 | 40 | 20 | 30 | M64X2 | 25 | M24X3 | 45 | M8 | 6,4 |
| 360/GM | 10 | 700 bar | 445 cm ³ | 685 | 405 | 280 | 40 | 20 | 30 | M64X2 | 25 | M24X3 | 45 | M8 | 7,6 |
| 360/HM | 10 | 700 bar | 556 cm ³ | 825 | 475 | 350 | 40 | 20 | 30 | M64X2 | 25 | M24X3 | 45 | M8 | 8,8 |
| 361/EM | 20 | 700 bar | 529 cm ³ | 450 | 290 | 160 | 60 | 20 | 30 | M84X2 | 30 | M30X3,5 | 50 | M10 | 11,1 |
| 361/FM | 20 | 700 bar | 728,2 cm ³ | 570 | 350 | 220 | 60 | 20 | 30 | M84X2 | 30 | M30X3,5 | 50 | M10 | 13,2 |
| 361/GM | 20 | 700 bar | 993 cm ³ | 730 | 430 | 300 | 60 | 20 | 30 | M84X2 | 30 | M30X3,5 | 50 | M10 | 16,1 |
| 361/HM | 20 | 700 bar | 1158,5 cm ³ | 830 | 480 | 350 | 60 | 20 | 30 | M84X2 | 30 | M30X3,5 | 50 | M10 | 18 |

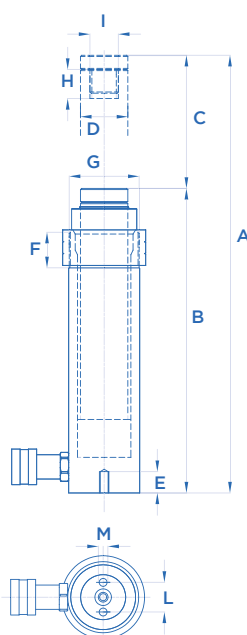

| ART. | ART. Pompa Manuale | | ART. Pompa Idropneumatica |
|--------|--------------------|------------|---------------------------|
| | 1 Velocità | 2 Velocità | |
| 359/EM | 358/A | 358/D | 357 |
| 359/FM | 358/A | 358/D | 357 |
| 359/GM | 358/A | 358/D | 357 |
| 359/HM | 358/A | 358/D | 357 |
| 360/EM | 358/A | 358/C | 357 |
| 360/FM | 358/A | 358/C | 357 |
| 360/GM | 358/A | 358/C | 357 |
| 360/HM | 358/A | 358/C | 357 |
| 361/EM | 358/A | 358/C | 357 |
| 361/FM | 358/A | 358/C | 357 |
| 361/GM | 358/A | 358/C | 357 |
| 361/HM | 358/B | 358/C | 357 |

359/EM - Portata 5 Ton.

~~€ 462,00~~ - € 273,00

360/EM - Portata 10 Ton.

~~€ 544,00~~ - € 322,00

361/EM - Portata 20 Ton.

~~€ 978,00~~ - € 579,00

359/FM - Portata 5 Ton.

~~€ 551,00~~ - € 326,00

360/FM - Portata 10 Ton.

~~€ 653,00~~ - € 387,00

361/FM - Portata 20 Ton.

~~€ 1.171,00~~ - € 694,00

359/GM - Portata 5 Ton.

~~€ 661,00~~ - € 391,00

360/GM - Portata 10 Ton.

~~€ 783,00~~ - € 464,00

361/GM - Portata 20 Ton.

~~€ 1.404,00~~ - € 832,00

359/HM - Portata 5 Ton.

~~€ 792,00~~ - € 468,00

360/HM - Portata 10 Ton.

~~€ 937,00~~ - € 555,00

361/HM - Portata 20 Ton.

~~€ 1.685,00~~ - € 998,00



CORSA LUNGA

| ART. | TON | Pressione | Capacità olio | A _{mm} | B _{mm} | C _{mm} | D _{mm} | E _{mm} | F _{mm} | G _{mm} | H _{mm} | I _{mm} | L _{mm} | M _{mm} | KG |
|---------------|-----|-----------|----------------------|-----------------|-----------------|-----------------|-----------------|-----------------|-----------------|-----------------|-----------------|-----------------|-----------------|-----------------|------|
| 362/EM | 30 | 700 bar | 702 cm ³ | 420 | 275 | 140 | 75 | 20 | 30 | M104X2 | 25 | M39X4 | 65 | M10 | 16,8 |
| 362/FM | 30 | 700 bar | 1005 cm ³ | 540 | 335 | 200 | 75 | 20 | 30 | M104X2 | 25 | M39X4 | 65 | M10 | 20,2 |
| 362/GM | 30 | 700 bar | 1305 cm ³ | 660 | 395 | 260 | 75 | 20 | 30 | M104X2 | 25 | M39X4 | 65 | M10 | 23,5 |
| 362/HM | 30 | 700 bar | 1606 cm ³ | 780 | 455 | 320 | 75 | 20 | 30 | M104X2 | 25 | M39X4 | 65 | M10 | 26,5 |
| 363/EM | 50 | 700 bar | 1177 cm ³ | 445 | 295 | 150 | 90 | 20 | 30 | M128X1,5 | 30 | M55X3 | 77 | M10 | 25 |
| 363/FM | 50 | 700 bar | 1570 cm ³ | 545 | 345 | 200 | 90 | 20 | 30 | M128X1,5 | 30 | M55X3 | 77 | M10 | 28,9 |
| 363/GM | 50 | 700 bar | 1962 cm ³ | 645 | 395 | 250 | 90 | 20 | 30 | M128X1,5 | 30 | M55X3 | 77 | M10 | 32,6 |
| 363/HM | 50 | 700 bar | 2355 cm ³ | 745 | 445 | 300 | 90 | 20 | 30 | M128X1,5 | 30 | M55X3 | 77 | M10 | 37,2 |

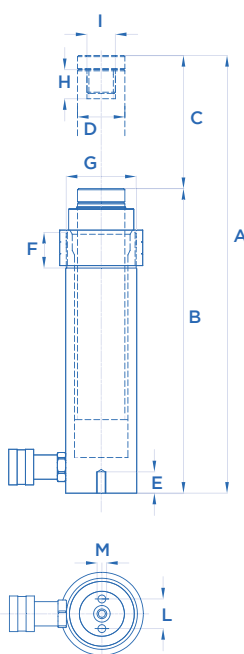

| ART. | ART. Pompa Manuale | | ART. Pompa Idropneumatica |
|---------------|--------------------|------------|---------------------------|
| | 1 Velocità | 2 Velocità | |
| 362/EM | 350/A | 358/C | 357 |
| 362/FM | 358/B | 358/C | 357 |
| 362/GM | 358/B | 358/C | 357 |
| 362/HM | 358/B | 358/C | 357 |
| 363/EM | 358/B | 358/C | 357 |
| 363/FM | 358/B | 358/C | 357 |
| 363/GM | 358/B | 358/C | 357 |
| 363/HM | 358/B | 358/C | 357 |

362/EM - Portata 30 Ton.
~~€ 1.139,00~~ - € 675,00

362/HM - Portata 30 Ton.
~~€ 1.969,00~~ - € 1.167,00

363/GM - Portata 50 Ton.
~~€ 2.197,00~~ - € 1.302,00

362/FM - Portata 30 Ton.
~~€ 1.368,00~~ - € 811,00

363/EM - Portata 50 Ton.
~~€ 1.529,00~~ - € 907,00

363/HM - Portata 50 Ton.
~~€ 2.638,00~~ - € 1.564,00

362/GM - Portata 30 Ton.
~~€ 1.641,00~~ - € 973,00

363/FM - Portata 50 Ton.
~~€ 1.831,00~~ - € 1.086,00

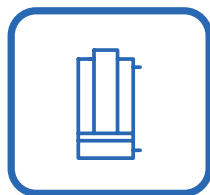

A DOPPIO EFFETTO

| ART. | ↑ TON | ↓ TON | Pressione | Capacità olio | A mm | B mm | C mm | D mm | E mm | F mm | G mm | H mm | I mm | L mm | M mm | KG |
|--------------|----------|----------|-----------|-----------------------|---------|---------|---------|---------|---------|---------|----------|---------|---------|---------|---------|------|
| 369 | 11 | 4 | 700 bar | 255,3 cm ³ | 445 | 285 | 160 | 35 | 10 | 25 | M59X2 | 45 | M20X2,5 | 23 | M8 | 5,5 |
| 369/A | 11 | 4 | 700 bar | 516 cm ³ | 800 | 470 | 330 | 35 | 10 | 25 | M59X2 | 45 | M20X2,5 | 23 | M8 | 8,7 |
| 369/D | 35 | 15 | 700 bar | 955 cm ³ | 540 | 350 | 190 | 60 | 14 | 35 | M104X2 | 45 | M20X2,5 | 60 | M10 | 17,5 |
| 369/E | 35 | 15 | 700 bar | 1582 cm ³ | 785 | 470 | 315 | 60 | 14 | 35 | M104X2 | 45 | M20X2,5 | 60 | M10 | 23,5 |
| 369/H | 55 | 24 | 700 bar | 1216 cm ³ | 470 | 320 | 150 | 75 | 20 | 30 | M128X1,5 | 50 | M30X3,5 | 65 | M10 | 28,2 |
| 369/I | 55 | 24 | 700 bar | 2001 cm ³ | 670 | 420 | 250 | 75 | 20 | 30 | M128X1,5 | 50 | M30X3,5 | 65 | M10 | 36 |

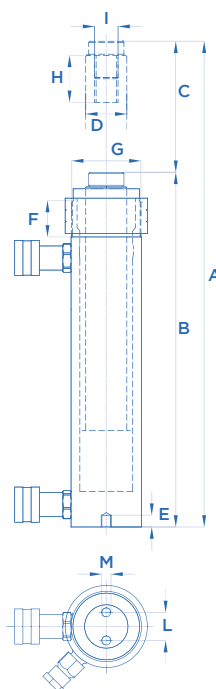

| ART. | ART. Pompa Manuale | | ART. Pompa Idropneumatica |
|--------------|--------------------|------------|---------------------------|
| | 1 Velocità | 2 Velocità | |
| 369 | 358/K | 358/L | 357/C |
| 369/A | 358/K | 358/L | 357/C |
| 369/D | 358/K | 358/L | 357/C |
| 369/E | | 358/L | 357/C |
| 369/H | | 358/L | 357/C |
| 369/I | | 358/L | 357/C |

369 - Portata 11 Ton.

~~€ 1.177,00~~ - € 698,00

369/A - Portata 11 Ton.

~~€ 1.556,00~~ - € 923,00

369/D - Portata 35 Ton.

~~€ 2.157,00~~ - € 1.279,00

369/E - Portata 35 Ton.

~~€ 2.517,00~~ - € 1.492,00

369/H - Portata 55 Ton.

~~€ 3.134,00~~ - € 1.858,00

369/I - Portata 55 Ton.

~~€ 3.611,00~~ - € 2.140,00



SEMPLICE EFFETTO CON PISTONE FORATO

| ART. | TON | Pressione | Capacità olio | A mm | B mm | C mm | D mm | E mm | F mm | G mm | H mm | I mm | L mm | M mm | N mm | KG |
|--------------|-----|-----------|----------------------|------|------|------|------|------|------|----------|------|---------|------|------|------|-----|
| 366 | 12 | 700 bar | 111 cm ³ | 265 | 200 | 65 | 40 | 10 | 25 | M69X2 | 20 | M28X1,5 | 50 | M5 | 20,5 | 4 |
| 366/A | 12 | 700 bar | 15 cm ³ | 68 | 60 | 8 | 40 | 10 | 25 | M69X2 | 20 | M28X1,5 | 50 | M5 | 20,5 | 1,6 |
| 366/B | 12 | 700 bar | 56,4 cm ³ | 152 | 122 | 32 | 40 | 10 | 25 | M69X2 | 20 | M28X1,5 | 65 | M5 | 20,5 | 3 |
| 367 | 24 | 700 bar | 471 cm ³ | 445 | 320 | 125 | 60 | 10 | 35 | M104X2 | 25 | M44X2 | 67 | M6 | 27 | 14 |
| 367/A | 24 | 700 bar | 70 cm ³ | 193 | 175 | 18 | 60 | 10 | 35 | M104X2 | 25 | M44X2 | 67 | M6 | 27 | 8,5 |
| 367/B | 37 | 700 bar | 150 cm ³ | 230 | 195 | 35 | 75 | 20 | 30 | M128X1,5 | 20 | M55X2 | 88 | M10 | 34 | 16 |
| 367/C | 37 | 700 bar | 760 cm ³ | 535 | 385 | 150 | 75 | 20 | 30 | M128X1,5 | 20 | M55X2 | 88 | M10 | 34 | 25 |

| ART. | ART. Pompa Manuale | | ART. Pompa Idropneumatica |
|--------------|--------------------|------------|---------------------------|
| | 1 Velocità | 2 Velocità | |
| 366 | 358/A | 358/C | 357 |
| 366/A | 358/A | 358/C | 357 |
| 366/B | 358/A | 358/C | 357 |
| 367 | 358/A | 358/C | 357 |
| 367/A | 358/A | 358/C | 357 |
| 367/B | 358/A | 358/C | 357 |
| 367/C | 358/A | 358/C | 357 |

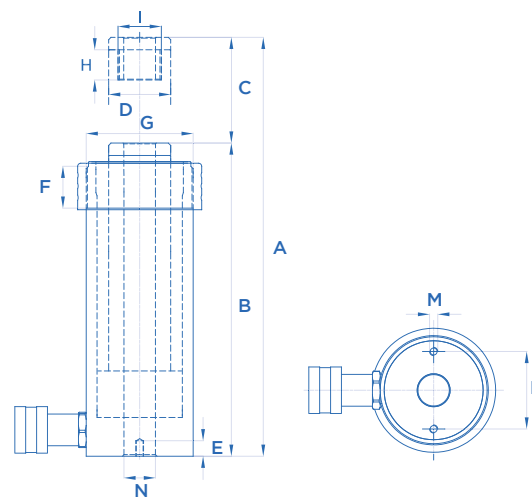

366 - Portata 12 Ton.
~~€ 904,00~~ - € 536,00

367 - Portata 24 Ton.
~~€ 1.395,00~~ - € 827,00

367/B - Portata 37 Ton.
~~€ 1.843,00~~ - € 1.093,00

366/A - Portata 12 Ton.
~~€ 830,00~~ - € 492,00

367/A - Portata 24 Ton.
~~€ 1.281,00~~ - € 760,00

367/C - Portata 37 Ton.
~~€ 2.157,00~~ - € 1.279,00

366/B - Portata 12 Ton.
~~€ 867,00~~ - € 514,00

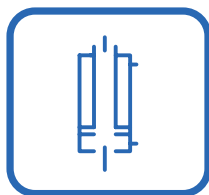

DOPPIO EFFETTO CON PISTONE FORATO

| ART. | ↑ TON | ↓ TON | Pressione | Capacità olio | A mm | B mm | C mm | D mm | E mm | F mm | G mm | H mm | I mm | L mm | M mm | N mm | KG |
|--------------|----------|----------|-----------|------------------------|---------|---------|---------|---------|---------|---------|----------|---------|---------|---------|---------|---------|----|
| 367/H | 24 | 14 | 700 bar | 301,4 cm ³ | 330 | 250 | 80 | 60 | 10 | 35 | M104X2 | 25 | M44X2 | 67 | M6 | 27 | 14 |
| 367/I | 24 | 14 | 700 bar | 753,6 cm ³ | 570 | 370 | 200 | 60 | 10 | 35 | M104X2 | 25 | M44X2 | 67 | M6 | 27 | 24 |
| 367/N | 37 | 22 | 700 bar | 471,2 cm ³ | 335 | 255 | 80 | 75 | 18 | 30 | M128X1,5 | 20 | M55X2 | 88 | M10 | 34 | 22 |
| 367/O | 37 | 22 | 700 bar | 1472,3 cm ³ | 675 | 425 | 250 | 75 | 18 | 30 | M128X1,5 | 20 | M55X2 | 88 | M10 | 34 | 34 |
| 367/R | 48 | 32 | 700 bar | 671,4 cm ³ | 360 | 270 | 90 | 90 | 20 | 30 | M160X3,5 | 25 | M76X3 | 98 | M12 | 54 | 37 |
| 367/S | 48 | 32 | 700 bar | 1790,4 cm ³ | 660 | 420 | 240 | 90 | 20 | 30 | M160X3,5 | 25 | M76X3 | 98 | M12 | 54 | 45 |



| ART. | ART. Pompa Manuale | | ART. Pompa Idropneumatica |
|--------------|--------------------|------------|---------------------------|
| | 1 Velocità | 2 Velocità | |
| 367/H | 358/K | 358/L | 357/C |
| 367/I | 358/K | 358/L | 357/C |
| 367/N | 358/K | 358/L | 357/C |
| 367/O | | 358/L | 357/C |
| 367/R | 358/K | 358/L | 357/C |
| 367/S | | 358/L | 357/C |

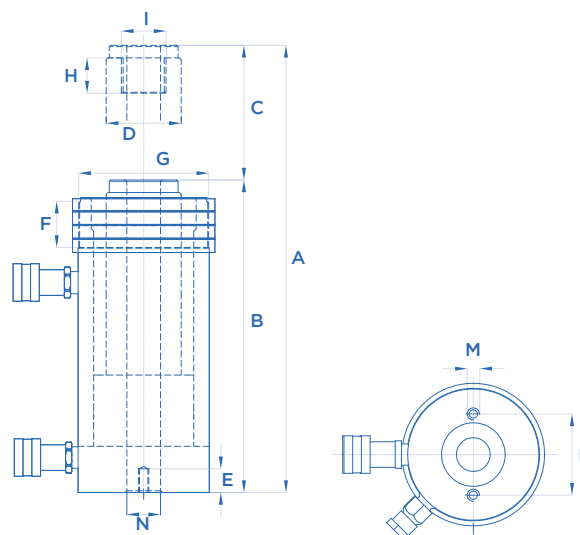

367/H - Portata 24 Ton.

€ ~~1.469,00~~ - € **871,00**

367/N - Portata 37 Ton.

€ ~~2.108,00~~ - € **1.250,00**

367/R - Portata 48 Ton.

€ ~~2.469,00~~ - € **1.464,00**

367/I - Portata 24 Ton.

€ ~~1.596,00~~ - € **946,00**

367/O - Portata 37 Ton.

€ ~~2.463,00~~ - € **1.460,00**

367/S - Portata 48 Ton.

€ ~~2.880,00~~ - € **1.707,00**

POMPE MANUALI COMPLETE DI TUBO FLESSIBILE



358/C

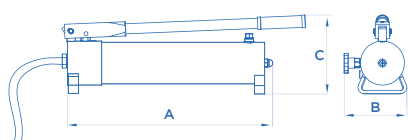

350/A

~~€ 445,00~~ - € 265,00

358/A

~~€ 494,00~~ - € 292,00

358/B

~~€ 855,00~~ - € 505,00

358/C

~~€ 1.049,00~~ - € 619,00

358/D

~~€ 1.556,00~~ - € 919,00

358/E

~~€ 2.609,00~~ - € 1.540,00

358/K

~~€ 1.236,00~~ - € 730,00

358/L

~~€ 2.315,00~~ - € 1.367,00

| ART. | Tipo pompa | Valvola a 4 vie | Pressione | Portata olio per pompata | | Capacità serbatoio | A mm | B mm | C mm | KG |
|--------------|-----------------|-----------------|-----------|--------------------------|----------------------|----------------------|------|------|------|------|
| 350/A | Ad una velocità | ✓ | 700 bar | 2,26 cm ³ | 2,26 cm ³ | 1100 cm ³ | 510 | 165 | 160 | 9,2 |
| 358/A | | | 700 bar | 2,26 cm ³ | 2,26 cm ³ | 650 cm ³ | 330 | 140 | 160 | 6,5 |
| 358/B | | | 700 bar | 3,5 cm ³ | 3,5 cm ³ | 2400 cm ³ | 500 | 165 | 195 | 13,5 |
| 358/K | | | 700 bar | 2,26 cm ³ | 2,26 cm ³ | 1000 cm ³ | 530 | 100 | 150 | 10 |
| 358/C | A due velocità | ✓ | 700 bar | 14,13 cm ³ | 3,07 cm ³ | 2400 cm ³ | 510 | 160 | 200 | 12,5 |
| 358/D | | | 520 bar | 26,3 cm ³ | 3,07 cm ³ | 4000 cm ³ | 520 | 200 | 250 | 24,5 |
| 358/E | | | 520 bar | 30,3 cm ³ | 3,07 cm ³ | 7500 cm ³ | 565 | 230 | 300 | 40 |
| 358/L | | | 700 bar | 14,13 cm ³ | 3,07 cm ³ | 2400 cm ³ | 560 | 120 | 220 | 21,5 |

POMPE IDROPNEUMATICHE COMPLETE DI TUBO FLESSIBILE E GIUNTO RAPIDO

357

~~€ 980,00~~ - € 579,00

357/A

~~€ 1.201,00~~ - € 710,00

357/B

~~€ 1.442,00~~ - € 852,00

357/C

~~€ 2.079,00~~ - € 1.229,00

357/D

~~€ 1.201,00~~ - € 710,00



357



357/C

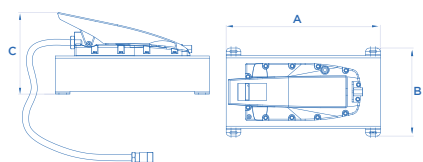

| ART. | Valvola a 4 vie | Pressione | Portata | Capacità serbatoio | A mm | B mm | C mm | KG |
|--------------|-----------------|-----------|-----------|----------------------|------|------|------|------|
| 357 | ✓ | 700 bar | 0,7 l/min | 1100 cm ³ | 295 | 110 | 170 | 6,3 |
| 357/A | | 520 bar | 1,4 l/min | 4500 cm ³ | 420 | 240 | 220 | 14 |
| 357/B | | 520 bar | 1,4 l/min | 8000 cm ³ | 420 | 240 | 220 | 19 |
| 357/C | | 700 bar | 1,1 l/min | 5000 cm ³ | 420 | 240 | 245 | 15,5 |
| 357/D | | 700 bar | 1,1 l/min | 4500 cm ³ | 420 | 240 | 220 | 14 |

PIASTRE DI BASE



BA/1

~~€ 166,00~~ - € 99,00

BA/2

~~€ 185,00~~ - € 110,00

BA/3

~~€ 207,00~~ - € 123,00

BA/4

~~€ 269,00~~ - € 159,00

BA/5

~~€ 312,00~~ - € 185,00

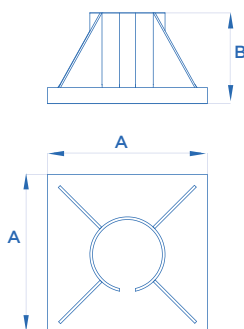

ART.

Compatibilità

A mm

B mm

BA/1

ART. 359/D • 359/DM • 359/EM • 359/FM • 359/GM • 359/HM

220

155

BA/2

ART. 360/D • 360/DM • 360/EM • 360/FM • 360/GM • 360/HM

220

155

BA/3

ART. 361/D • 361/DM • 361/EM • 361/FM • 361/GM • 361/HM

220

155

BA/4

ART. 362/D • 362/DM • 362/EM • 362/FM • 362/GM • 362/HM

300

170

BA/5

ART. 363/D • 363/DM • 363/EM • 363/FM • 363/GM • 363/HM

300

170

MANOMETRI IN GLICERINA



M/1

~~€ 137,00~~ - € 81,00

M/2

~~€ 199,00~~ - € 118,00

ART.

Scala

Diametro

M/1

0-1000 bar

63 mm

M/2

0-1000 bar

100 mm

ADATTATORI PER MANOMETRO

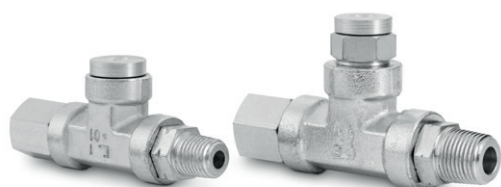

PM/1 ART. M/1

~~€ 45,00~~ - € 27,00

PM/2 ART. M/2

~~€ 55,50~~ - € 33,00

**CARRELLO
PORTA ATTREZZI**

109/A - Portata 120 Kg

~~€ 183,00~~ - € 107,00

109/AS - Portata 120 Kg

~~€ 190,00~~ - € 112,00



109/A



109/AS - SMONTABILE



109/A • 109/AS | 120 kg | 700 | 750 | 350 | 60

**CARRELLO
PORTA ATTREZZI
TIPO PESANTE**

109/B - Portata 150 Kg

~~€ 236,00~~ - € 139,00

109/BS - Portata 150 Kg

~~€ 246,00~~ - € 145,00



109/B



109/BS - SMONTABILE



109/B • 109/BS | 150 kg | 800 | 750 | 420 | 80

**CARRELLO
PORTA ATTREZZI
TIPO PESANTE
CON CASSETTO**

109/C - Portata 150 Kg

~~€ 303,00~~ - € 179,00

109/CS - Portata 150 Kg

~~€ 316,00~~ - € 187,00



109/C



109/CS - SMONTABILE



109/C • 109/CS* | 150 kg | 800 | 750 | 420 | 80

(*) Salvo esaurimento scorte

**CARRELLO GIGANTE
A TRE PIANI**

208 - Portata 180 Kg

~~€ 345,00~~ - € 204,00

208/S - Portata 180 Kg

~~€ 366,00~~ - € 217,00



208



208/S - SMONTABILE



208 • 208/S | 180 kg | 1000 | 830 | 600 | 125

CARRELLO GIGANTE
A TRE PIANI
CON CASSETTO

209 - Portata 180 Kg

~~€ 405,00~~ - € 239,00

209/S - Portata 180 Kg

~~€ 424,00~~ - € 251,00



209

209/S - SMONTABILE



209 • 209/S* | 180 kg | 1000 | 830 | 600 | 125

(*) Salvo esaurimento scorte

CARRELLO
CON SPONDA

207 - Portata 250 Kg

~~€ 389,00~~ - € 229,00



207 | 250 kg | 1000 | 900 | 600 | 125

CARRELLO CON SPONDE
E RETE METALLICA
PERIMETRALE

211 - Portata 250 Kg

~~€ 453,00~~ - € 269,00



211

211/A - Portata 250 Kg

~~€ 546,00~~ - € 325,00



211/A - SMONTABILE



211 | 250 kg | 1000 | 850 | 600 | 125
211/A | 250 kg | 1020 | 950 | 600 | 125

**CARRELLO CHIUSO
PORTA ATTREZZI
A QUATTRO PIANI
CON SERRATURA**

210 - Portata 200 Kg

~~€ 546,00~~ - € 320,00

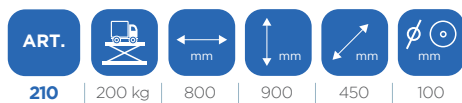

**CARRELLO
ECOLOGICO**

600 - Portata 75 Kg

~~€ 512,00~~ - € 299,00



CARRELLI PER MOVIMENTAZIONE

**CARRELLO
MILLEUSI**

092 - Portata 300 kg

~~€ 343,00~~ - € 199,00

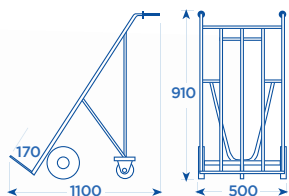

**CARRELLO
PORTA BOMBOLE**

095 - Portata 200 kg

~~€ 256,00~~ - € 150,00

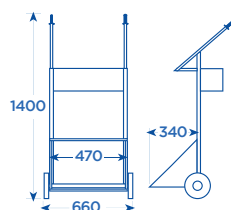

CARRELLO PORTA BOMBOLA

095/A - Portata 200 kg

~~€ 240,00~~ - € 140,00

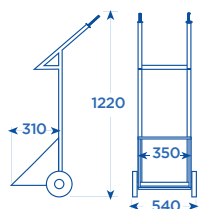

ART. 095/A | 200 kg | 250

CARRELLO PORTA SACCHI

212 - Portata 200 kg

~~€ 185,00~~ - € 109,00

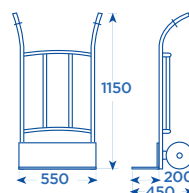

ART. 212 | 200 kg | 200

CARRELLO PORTA CASSE

213 - Portata 200 kg

~~€ 199,00~~ - € 117,00

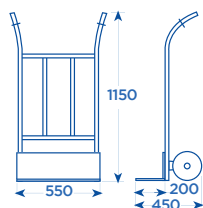

ART. 213 | 200 kg | 200

CARRELLO PORTA CASSE

214 - Portata 100 kg

~~€ 161,00~~ - € 95,00

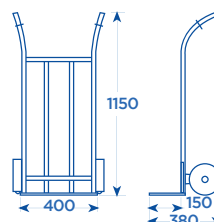

ART. 214 | 100 kg | 200

**CARRELLO
MULTIUSO PER
TRASPORTO SU SCALE**

214/A - Portata 250 kg

~~€ 335,00~~ - € 197,00

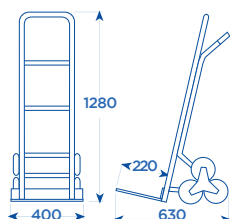

ART. mm
214/A | 250 kg | 150

**CARRELLO
PORTA CASSE
STRETTO**

214/B - Portata 250 kg

~~€ 263,00~~ - € 155,00

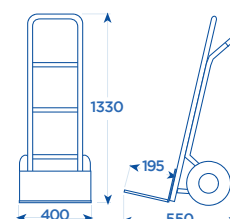

ART. mm
214/B | 250 kg | 260

**CARRELLO
PORTA CASSE
LARGO**

214/C - Portata 250 kg

~~€ 288,00~~ - € 170,00

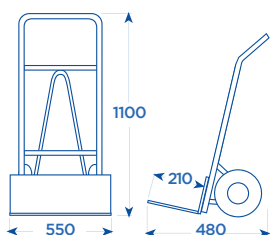

ART. mm
214/C | 250 kg | 260

**CARRELLO
PORTA SACCHI E
PORTA FUSTI**

214/D - Portata 250 kg

~~€ 311,00~~ - € 183,00

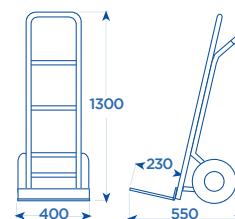

ART. mm
214/D | 250 kg | 260

Vengono forniti in versione smontabile per una più facile e razionale gestione del trasporto e dell'immagazzinaggio. Possono essere forniti con pianale in lamiera o con pianale in legno. Tutti i cassetti sono dotati di serratura e lo scorrimento avviene su guide con cuscinetto. Verniciatura a polvere epossidica.

1000 - Portata 700 kg
~~€ 556,00~~ - € 329,00

1000/PL - Portata 700 kg
~~€ 637,00~~ - € 377,00

1001 - Portata 600 kg
~~€ 658,00~~ - € 389,00

1001/PL - Portata 600 kg
~~€ 777,00~~ - € 462,00

1002 - Portata 600 kg
~~€ 807,00~~ - € 479,00

1002/PL - Portata 600 kg
~~€ 923,00~~ - € 545,00

1003 - Portata 400 kg
~~€ 1.026,00~~ - € 605,00

1003/PL - Portata 400 kg
~~€ 1.141,00~~ - € 677,00

1004 - Portata 400 kg
~~€ 1.172,00~~ - € 695,00

1004/PL - Portata 400 kg
~~€ 1.281,00~~ - € 760,00



| ART. |  Pianale in legno | Numero di cassetti |  mm |  mm |  mm |
|----------------|--|--------------------|--|--|--|
| 1000 | 700 kg | 1 | 1000 | 850 | 700 |
| 1000/PL | 700 kg ✓ | 1 | 1000 | 880 | 700 |
| 1001 | 600 kg | 1 | 1500 | 850 | 700 |
| 1001/PL | 600 kg ✓ | 1 | 1500 | 880 | 700 |
| 1002 | 600 kg | 2 | 1500 | 850 | 700 |
| 1002/PL | 600 kg ✓ | 2 | 1500 | 880 | 700 |
| 1003 | 400 kg | 2 | 2000 | 850 | 700 |
| 1003/PL | 400 kg ✓ | 2 | 2000 | 880 | 700 |
| 1004 | 400 kg | 3 | 2000 | 850 | 700 |
| 1004/PL | 400 kg ✓ | 3 | 2000 | 880 | 700 |

CARRELLO A QUATTRO RIPIANI, COMPLETO PANNELLO PORTAUTENSILI

C51

~~€ 778,00~~ - € 458,00

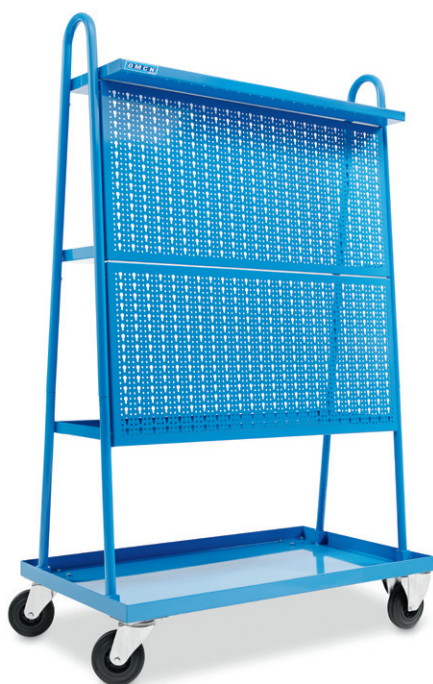
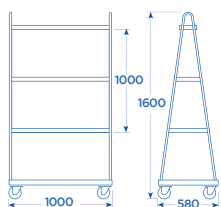

CARRELLO A QUATTRO RIPIANI, COMPLETO DI DOPPIO PANNELLO PORTAUTENSILI

C51/A

~~€ 849,00~~ - € 499,00

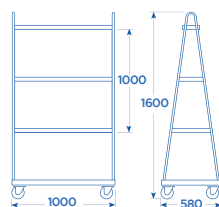

CARRELLO A DUE RIPIANI, COMPLETO PANNELLO PORTAUTENSILI

C52

~~€ 1041,00~~ - € 619,00

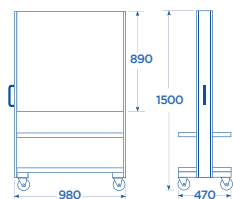

SCRIVIMPIEDI

1108

~~€ 773,00~~ - € 457,00

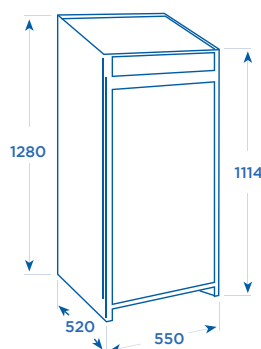

Salvo esaurimento scorte

099 - Portata 150 kg

~~€ 127,00~~ - € 75,00



| | | | |
|-------|--------|------|-----|
| ART. | | | |
| 099 | 150 kg | 1000 | 440 |
| 099/B | 150 Kg | 1000 | 440 |

099/B - Portata 150 kg

~~€ 215,00~~ - € 127,00



**STRUTTURA IN TUBOLARE
E SCHIENALE COMPLETAMENTE IMBOTTITO**

CASSETTI

1011

~~€ 165,00~~ - € 98,00



| | | |
|-----|-----|-----|
| | | |
| 130 | 530 | 400 |

PANNELLI



| | | | |
|------|---|------|-----|
| ART. | | | |
| 1050 | | 940 | 440 |
| 1051 | | 975 | 975 |
| 1052 | ✓ | 975 | 870 |
| 1053 | ✓ | 1445 | 870 |

1050

~~€ 85,00~~ - € 51,00

1051

~~€ 153,00~~ - € 91,00

1052

~~€ 176,00~~ - € 104,00

1053

~~€ 217,00~~ - € 129,00

GANCI

1070 - 200 mm

~~€ 1,49~~ - € 1,00

1071 - 150 mm

~~€ 1,49~~ - € 1,00

1072 - 120 mm

~~€ 1,45~~ - € 1,00

1073 - 80 mm

~~€ 1,39~~ - € 1,00

1074 - 60 mm

~~€ 1,39~~ - € 1,00

1075 - CON OCCHIELLO

~~€ 1,39~~ - € 1,00

1076 - 150 mm

~~€ 4,10~~ - € 3,00

1077 - 100 mm

~~€ 4,10~~ - € 3,00

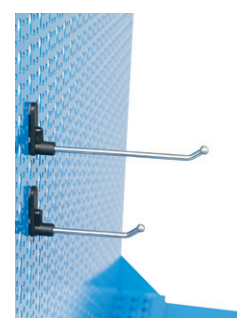
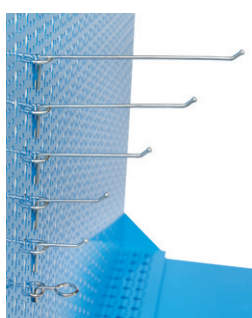

- Ferma ruota anteriore a sbalzo per agevolare il posizionamento della moto.
- **Morsa manuale in versione ribassata di serie su tutti i modelli.**
- Sistema di scorrimento su rulli pieni.
- **Scivolo retrattile per ridurre l'ingombro a terra quando il banco è sollevato.**
- Perni completi di ingrassatori.
- Finestra posteriore estraibile per facilitare l'estrazione della ruota.
- Protezione centrale antiscivolo in alluminio.
- Vaschette porta oggetti di serie.
- Dotati di cremagliera meccanica dentata di sicurezza.



196/P - Portata 500 kg

€ ~~2.470,00~~ - € **1.475,00**

CON POMPA IDRAULICA

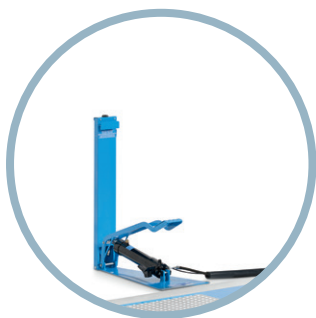

196/PI - Portata 500 kg

€ ~~3.347,00~~ - € **1.990,00**

CON POMPA IDROPNEUMATICA



196/PL - Portata 500 kg

€ ~~3.980,00~~ - € **2.340,00**

CON POMPA ELETTROIDRAULICA

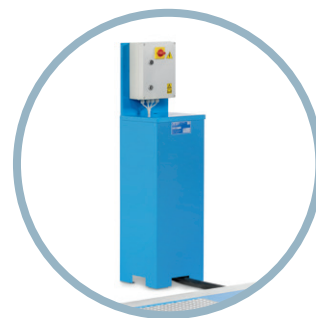

| ART. | | | | Motore trifase | |
|--------|--------|-------|--------|----------------|-----|
| 196/P | 500 Kg | 6 bar | | | 210 |
| 196/PI | 500 Kg | 6 bar | | | 200 |
| 196/PL | 500 Kg | 6 bar | 1,5 KW | 400V • 50HZ | 230 |

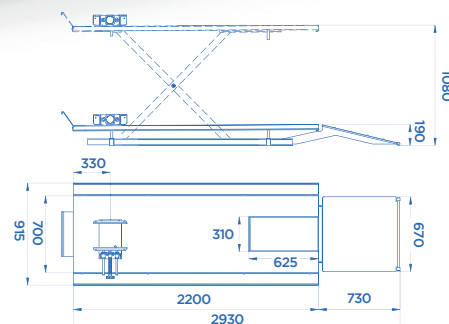

- Ferma ruota anteriore a sbalzo per agevolare il posizionamento della moto.
- Morsa manuale in versione ribassata di serie su tutti i modelli.
- **La struttura del basamento garantisce massima stabilità e minimo ingombro a terra.**
- Finestra posteriore estraibile per facilitare l'estrazione della ruota (196/A - 196/B).
- Pompa idraulica a pedale ad innesto diretto per ridurre il tempo necessario al sollevamento (196 - 196/A).
- Sistema di sollevamento totalmente pneumatico dotato di cremagliera meccanica ad inserimento automatico (196/B).

CLASSIC LINE



196 - Portata 500 kg

~~€ 2.184,00~~ - € 1.290,00

196/A - Portata 500 kg

~~€ 2.419,00~~ - € 1.429,00

CON POMPA IDRAULICA

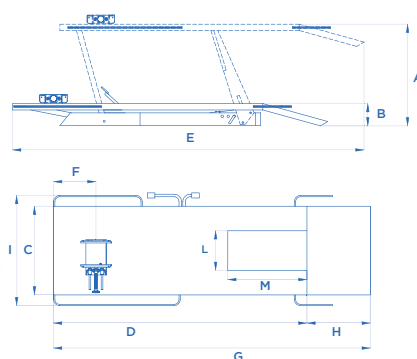

| ART. | | A mm | B mm | C mm | D mm | E mm | F mm | G mm | H mm | I mm | L mm | M mm | KG |
|-------|--------|------|------|------|------|------|------|------|------|------|------|------|-----|
| 196 | 500 Kg | 770 | 170 | 700 | 2000 | 2750 | 330 | 2500 | 500 | 870 | 300 | 640 | 165 |
| 196/A | 500 Kg | 770 | 170 | 700 | 2200 | 2900 | 330 | 2700 | 500 | 870 | 300 | 640 | 175 |

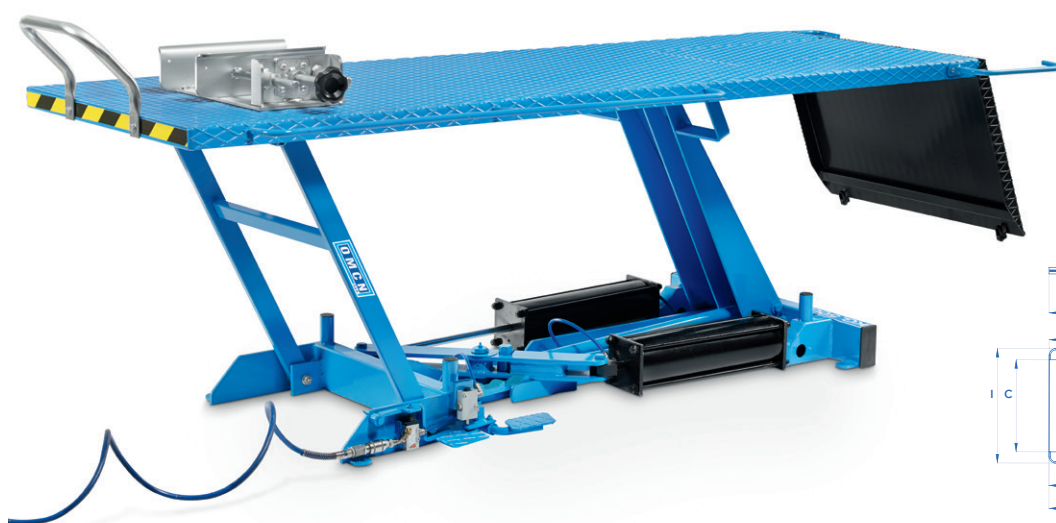

196/B - Portata 500 kg

~~€ 3.523,00~~ - € 2.081,00

CON POMPA PNEUMATICA

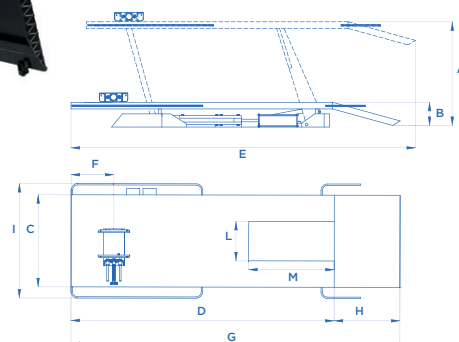

| ART. | | | A mm | B mm | C mm | D mm | E mm | F mm | G mm | H mm | I mm | L mm | M mm | KG |
|-------|--------|-------|------|------|------|------|------|------|------|------|------|------|------|-----|
| 196/B | 500 Kg | 8 bar | 730 | 190 | 700 | 2200 | 2800 | 330 | 2700 | 500 | 870 | 300 | 640 | 195 |

561

~~€ 146,00~~ - € 86,00

CAVALLETTO DI STAZIONAMENTO LIBERA RUOTA ANTERIORE A BRACCETTI SNODATI



Salvo esaurimento scorte

562

~~€ 159,00~~ - € 93,00

CAVALLETTO DI STAZIONAMENTO LIBERA RUOTA POSTERIORE REGISTRABILE IN ALTEZZA E IN LARGHEZZA COMPLETO DI BRACCETTI DI APPOGGIO E BRACCETTI A FORCELLA



Salvo esaurimento scorte

562/A

~~€ 130,00~~ - € 77,00

CAVALLETTO DI STAZIONAMENTO LIBERA RUOTA POSTERIORE REGISTRABILE IN LARGHEZZA COMPLETO DI BRACCETTI DI APPOGGIO E BRACCETTI A FORCELLA



Salvo esaurimento scorte

566

~~€ 530,00~~ - € 310,00

CAVALLETTO ROTATIVO UNIVERSALE PER LA REVISIONE MOTORI MOTOCICLI COMPLETO DI FLANGIA UNIVERSALE CON ATTACCHI REGOLABILI

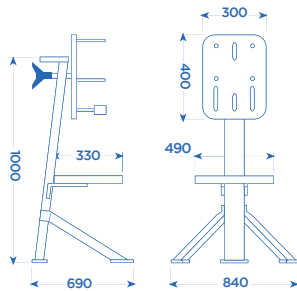

560 - 560/A

~~€ 465,00~~ - € 272,00

TRAVESSA DI SUPPORTO CON FUNZIONAMENTO A CRICCO, DOTATA DI COPPIA DI BRACCETTI REGOLABILI E REGISTRABILI IN ALTEZZA E DI TAMPONI IN GOMMA



563

~~€ 133,00~~ - € 429,00

MORSA PNEUMATICA

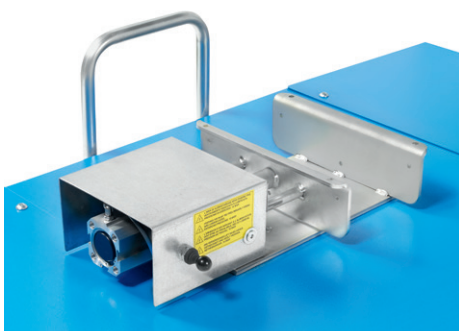

563/A

~~€ 189,00~~ - € 111,00

MORSA RIBALTABILE BLOCCA RUOTA



563/B

~~€ 307,00~~ - € 180,00

MORSA A L

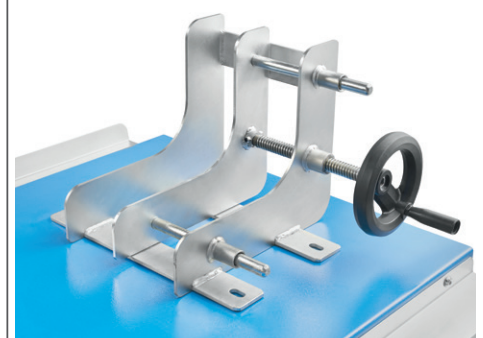

101 - Portata 12 Ton.

~~€ 1.112,00~~ - € 657,00



105 - Portata 5 Ton.

~~€ 848,00~~ - € 501,00



102 - Portata 12 Ton.

~~€ 1.028,00~~ - € 608,00



353 - Portata 12 Ton.

~~€ 1.014,00~~ - € 599,00



102 EXPORT - Portata 12 Ton.

~~€ 964,00~~ - € 570,00



355 - Portata 6 Ton.

~~€ 793,00~~ - € 469,00



ART.

A mm

B mm

101

320

480

102

320

480

102
EXPORT

320

480

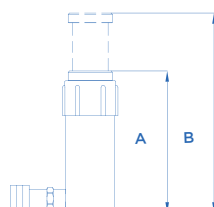

ART.

A mm

B mm

105

265

380

353

360

520

355

290

410

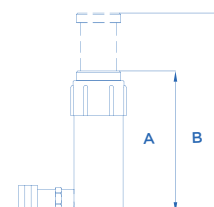



100 - Portata 20 Ton.

~~€ 1.632,00~~ - € **965,00**

100/A - Portata 30 Ton.

€ 1.923,00 - € **1.136,00**

100/B - Portata 50 Ton.

~~€ 2.762,00~~ - € **1.632,00**

100/C - Portata 80 Ton.

~~€ 3.579,00~~ - € **2.115,00**

100/D - Portata 120 Ton.

~~€ 5.061,00~~ - € **2.990,00**



| ART. | TON | A mm | B mm |
|-------|-----|------|------|
| 100 | 20 | 310 | 440 |
| 100/A | 30 | 310 | 440 |
| 100/B | 50 | 330 | 465 |
| 100/C | 80 | 340 | 480 |
| 100/D | 120 | 320 | 460 |

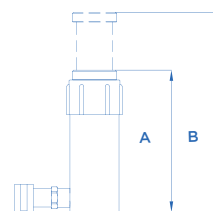

CPT

~~€ 107,00~~ - € **64,00**

CARRELLO A DUE PIANI



CM

~~€ 104,00~~ - € **62,00**

CASSETTA IN METALLO



350/A

POMPA MANUALE
COMPLETA DI TUBO FLESSIBILE

~~€ 445,00~~ - € 265,00

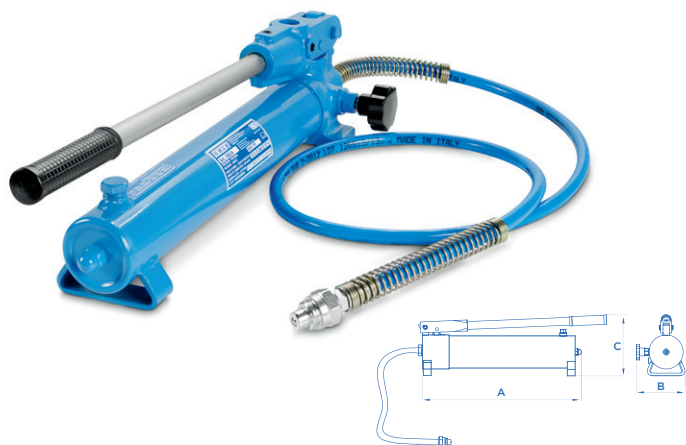

| Tipo pompa | Pressione | Portata olio per pompata | Capacità serbatoio | A mm | B mm | C mm | KG |
|-----------------|-----------|--------------------------|----------------------|------|------|------|-----|
| Ad una velocità | 700 bar | 2,26 cm ³ | 1100 cm ³ | 510 | 165 | 160 | 9,2 |

357

POMPA IDROPNEUMATICA
COMPLETA DI TUBO FLESSIBILE
E GIUNTO RAPIDO

~~€ 980,00~~ - € 579,00



| Pressione | Portata | Capacità serbatoio | A mm | B mm | C mm | KG |
|-----------|-----------|----------------------|------|------|------|-----|
| 700 bar | 0,7 l/min | 1100 cm ³ | 295 | 110 | 170 | 6,3 |

108 - 12 Ton.

~~€ 267,00~~ - € 158,00



PISTONI SPINGENTI

| ART. | TON | A mm | B mm |
|-------|-----|------|------|
| 108 | 12 | 150 | 230 |
| 108/A | 6 | 150 | 230 |
| 350/C | 12 | 400 | 630 |

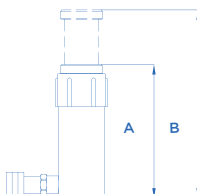

350/C - 12 Ton.

~~€ 357,00~~ - € 211,00



350/D - 6 Ton.

~~€ 353,00~~ - € 209,00



351 - 6 Ton.

~~€ 399,00~~ - € 236,00



PISTONI TIRANTI

| ART. | TON | A mm | B mm |
|-------|-----|------|------|
| 350/D | 6 | 530 | 350 |
| 351 | 6 | 770 | 470 |

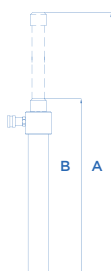

106/A - Portata 6 Ton.

~~€ 578,00~~ - € 342,00



106/B - Portata 4 Ton.

~~€ 373,00~~ - € 221,00



PISTONI TIRANTI

| ART. | TON | A mm | B mm |
|-------|-----|------|------|
| 106/A | 6 | 610 | 395 |
| 106/B | 4 | 460 | 310 |

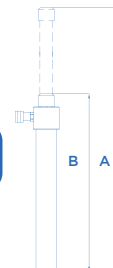

106/B1

~~€ 80,00~~ - € 48,00

N. 2 CATENE - FILO Ø 7



096

~~€ 99,00~~ - € 59,00

BATTITOIO A CONTRACCOLPO



290 - Portata 1 Ton.

~~€ 223,00~~ - € 132,00

ALLARGATORE IDRAULICO A CUNEO



096/A

~~€ 633,00~~ - € 374,00

BATTITOIO A CONTRACCOLPO
CORREDATO DI GANCI SPECIALI ED
INNESTO PER MORSETTI

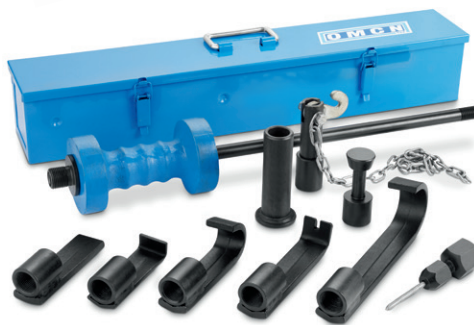

350/E

~~€ 144,00~~ - € 86,00



321

~~€ 239,00~~ - € 142,00

GANCIO A DOPPIA PRESA
(MANINA) CON ATTACCO FILETTATO



322

~~€ 233,00~~ - € 138,00

OCCHIELLO PER AGGANCIAMENTO
CATENA AL PISTONE



324

~~€ 141,00~~ - € 84,00

ATTACCO SPECIALE PER BANCHI
DI QUADRATURA



CARRELLO JOLLY



250/A - Portata 800 kg

~~€ 586,00~~ - € 346,00

250/B - Portata 1200 kg

~~€ 736,00~~ - € 435,00

| ART. | | | | | |
|-------|---------|-----|-----|------|-----|
| | mm | mm | mm | mm | mm |
| 250/A | 800 Kg | 600 | 330 | 1300 | 200 |
| 250/B | 1200 kg | 600 | 300 | 1880 | 200 |

250/A • 250/B - con 2 ruote frenanti

CAVALLETTO MULTIPRATIC

274

~~€ 736,00~~ - € 435,00

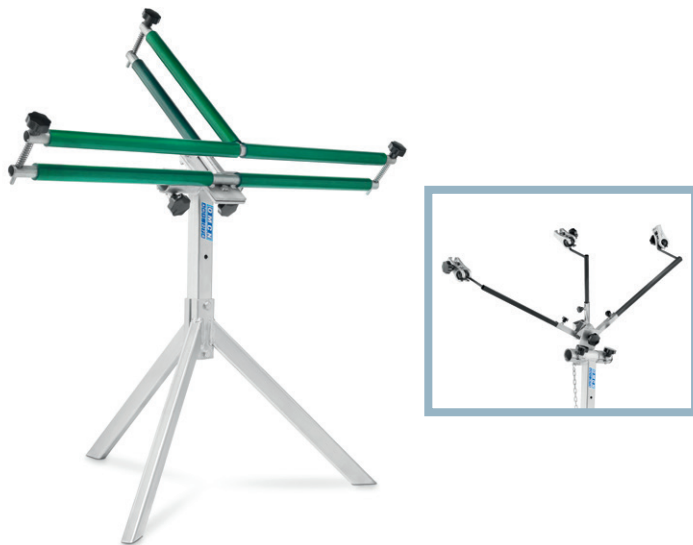

CAVALLETTO POLIFUNZIONALE

274/A

~~€ 643,00~~ - € 380,00



TRAVERSA REGOLABILE

SUPER
CONDOR



275

~~€ 390,00~~ - € 230,00

275/A

~~€ 514,00~~ - € 304,00

| ART. | | MAX | MIN |
|--------|--------|------|-----|
| | mm | mm | mm |
| 275 | 500 kg | 1500 | 920 |
| 275/A* | 500 Kg | 1500 | 920 |

(*) Salvo esaurimento scorte

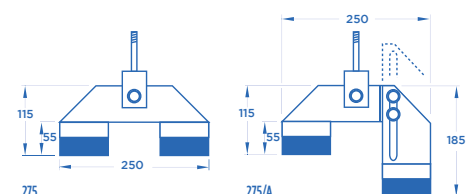

STRUMENTO DI MISURAZIONE TELESCOPICO

**ME.TE.
CAR**



379

~~€ 565,00~~ - € 334,00



CAVALLETTO SPEEDY
REGOLAZIONE A TRE POSIZIONI

381

~~€ 236,00~~ - € 139,00

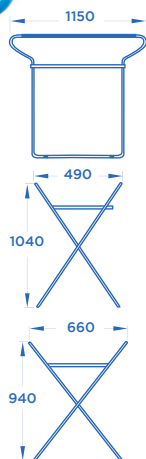

CAVALLETTO MAXI SPEEDY
A PLURIREGOLAZIONI

381/A

~~€ 270,00~~ - € 160,00

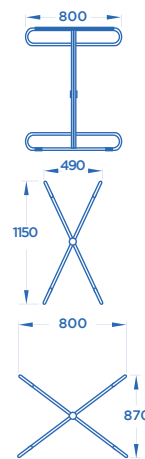

CARRELLO PER RECUPERO VETTURE
DA ISSARE SU CARROATTREZZI

388/C

~~€ 678,00~~ - € 405,00

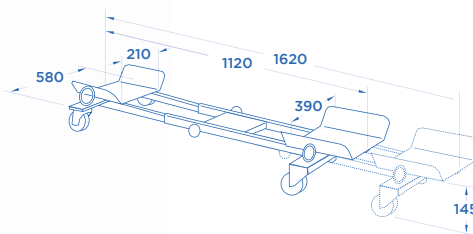

SOCCORSO

ART. **388/C** | 700 Kg | 100 mm

Salvo esaurimento scorte

SLALOM

Per manovrare e posizionare ogni tipo di vettura in spazi ristretti. Particolarmente indicato per carrozzerie, saloni d'auto, officine di riparazione e garages.

Esecuzione con pedale destro o sinistro per la risoluzione di ogni tipo di problema e la possibilità d'impiego anche con ruote sottosterzo.

I rulli e la struttura di base del carrello sono stati studiati per sollevare Pneumatici (MAX) fino a **220 mm.** di larghezza.



388

~~€ 657,00~~ - € 389,00 CAD.

Per manovrare e posizionare ogni tipo di vettura in spazi ristretti. Particolarmente indicato per carrozzerie, saloni d'auto, officine di riparazione e garages. Esecuzione con pedale destro o sinistro per la risoluzione di ogni tipo di problema e la possibilità d'impiego anche con ruote sottosterzo.

I rulli e la struttura di base del carrello sono stati studiati per sollevare pneumatici (MAX) fino a **280 mm.** di larghezza.

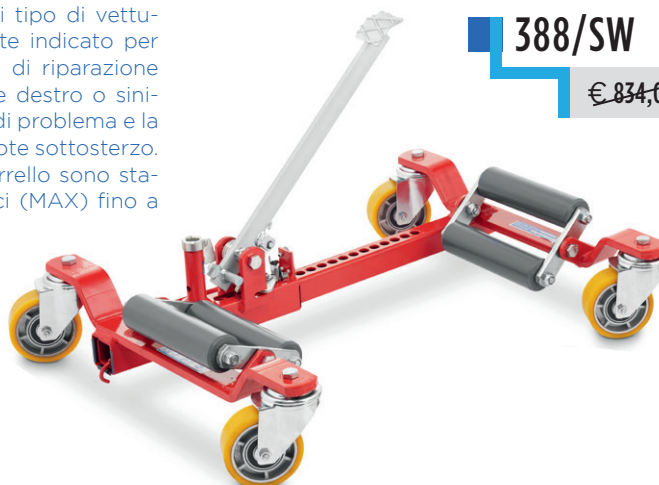

388/SW

~~€ 834,00~~ - € 494,00 CAD.

Attrezzo per carico e scarico di autovetture sinistrate per qualsiasi tipo di carroattrezzi.

I rulli e la struttura di base del carrello sono stati studiati per sollevare pneumatici fino a **220 mm.** di larghezza.

Speciale per carroattrezzi.



388/A

~~€ 718,00~~ - € 428,00 CAD.

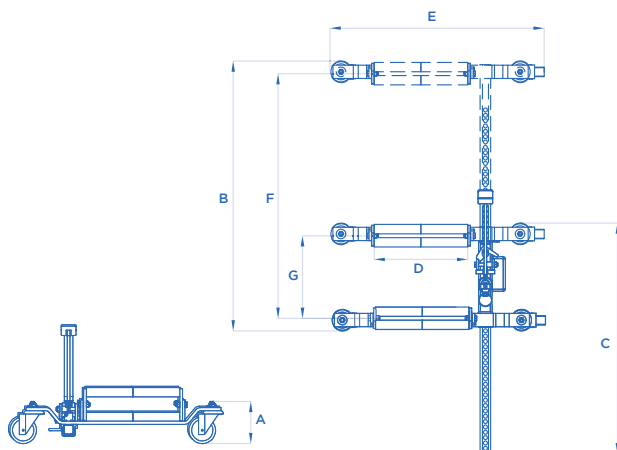

| ART. | | A mm | B mm | C mm | D mm | E mm | F mm | G mm | KG |
|--------|--------|------|------|------|------|------|------|------|----|
| 388 | 550 Kg | 150 | 820 | 710 | 200 | 635 | 650 | 220 | 19 |
| 388/SW | 550 Kg | 150 | 820 | 710 | 200 | 635 | 650 | 220 | 21 |
| 388/A | 550 Kg | 130 | 820 | 710 | 200 | 400 | 650 | 220 | 18 |

**PINZA AUTOBLOCCANTE
AUTOMATICA**

251

~~€ 233,00~~ - € 138,00

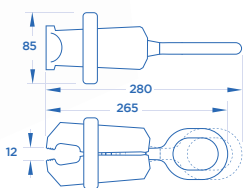

**PINZA AUTOBLOCCANTE
AUTOMATICA A TENAGLIA**

276

~~€ 224,00~~ - € 133,00

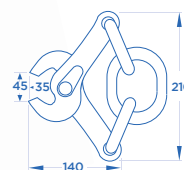

**PINZA AUTOBLOCCANTE A
TIRAGGIO PLURIDIREZIONALE**

277

~~€ 241,00~~ - € 143,00

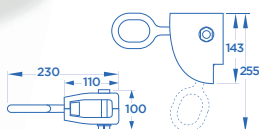

**MINI PINZA AUTOBLOCCANTE
A TIRAGGIO PLURIDIREZIONALE**

277/A

~~€ 212,00~~ - € 126,00

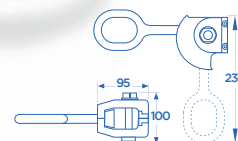

**PIASTRA PLURIFORATA PER
TRAZIONE TELAIO**

278

~~€ 78,00~~ - € 47,00

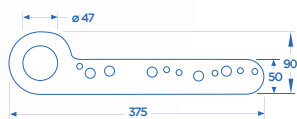
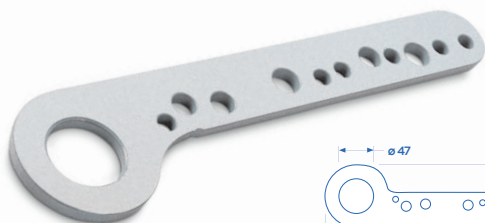

**MORSETTO AUTOSERRANTE
DI TRAZIONE (MM. 100)**

279 - 279/A

~~€ 212,00~~ - € 126,00 CAD.

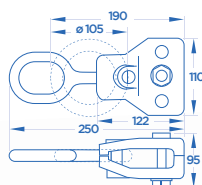

279

279/A

MORSETTO AUTOSERRANTE PER AGGOCCIOLATOI (MM. 70)

280 - 280/A

~~€ 199,00~~ - € 118,00 CAD.

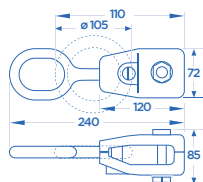

280

280/A

MORSETTO AUTOSERRANTE DI TRAZIONE (MM. 45)

281 - 281/A

~~€ 130,00~~ - € 77,00 CAD.

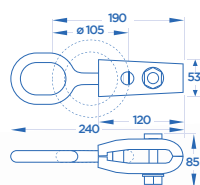

281

281/A

MORSETTO AUTOSERRANTE DI TRAZIONE A ANGOLO RETTO

282 - 282/A

~~€ 309,00~~ - € 183,00 CAD.



282

282/A

BRACCIO A GANCIO CON TRE ATTACCHI ADATTABILI, DI CUI UNO FILETTATO

285

~~€ 302,00~~ - € 179,00

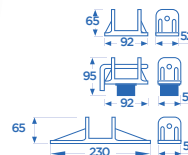

MORSETTO A DOPPIO BRACCIO MULTIUSO

393

~~€ 116,00~~ - € 69,00



MORSETTO AUTOBLOCCANTE AUTOMATICO CON GANASCE RIPORTATE (MM. 60)

295/SP

~~€ 319,00~~ - € 189,00



**MORSETTO AUTOBLOCCANTE AUTOMATICO
CON GANASCE RIPORTATE (MM. 100)**

296/SP

~~€ 348,00~~ - € 206,00

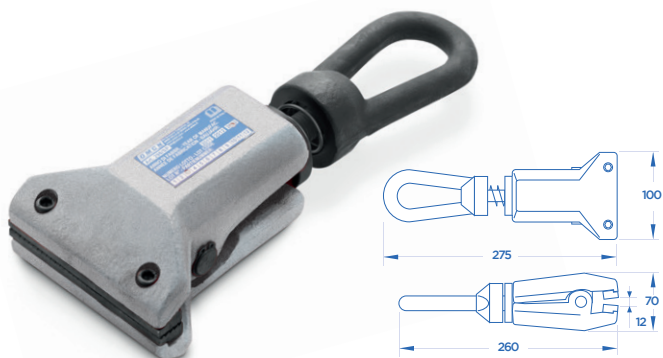

MORSETTO PICCOLO

297

~~€ 110,00~~ - € 65,00



MORSETTO A TENAGLIA

299/D

~~€ 479,00~~ - € 283,00



MORSETTO A TENAGLIA

299/H

~~€ 549,00~~ - € 324,00 CAD.



MORSETTO A TENAGLIA

299/M

~~€ 295,00~~ - € 175,00

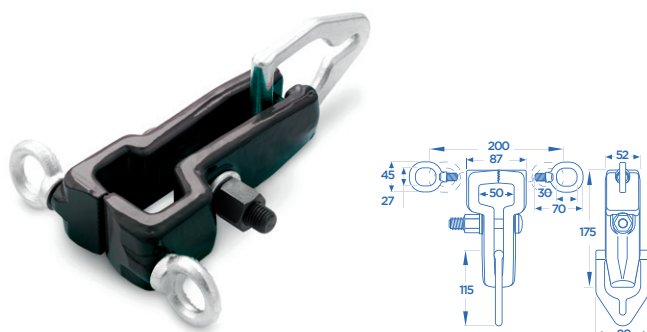

MORSETTO A TENAGLIA

299/N

~~€ 142,00~~ - € 84,00

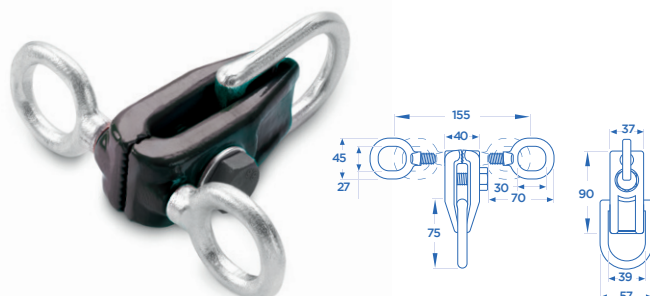

STAFFATORE PER CINGHIE E CATENE



299/0

~~€ 100,00~~ - € 59,00



610

~~€ 292,00~~ - € 173,00

Cinghie in poliestere ad elevata resistenza. Particolarmente indicate per operazioni di tiro in carrozzeria, ben si adattano a molteplici e svariati impieghi. L'estrema flessibilità, duttilità e leggerezza, unite alla elevata capacità ed alla sicurezza d'impiego, ne fanno un indispensabile strumento di lavoro. Le asole terminali rinforzate ben si accoppiano con ganci e catene di nostra produzione.



| ART. | mm |
|--------|------|
| RIF. A | 800 |
| RIF. B | 1200 |
| RIF. C | 1800 |
| RIF. D | 1000 |

325 - 1.500 mm

~~€ 45,50~~ - € 27,00

325/B - 2.500 mm

~~€ 56,00~~ - € 34,00

325/A - 2.000 mm

~~€ 51,00~~ - € 31,00

325/C - 3.000 mm

~~€ 63,00~~ - € 38,00

CAVO SICURO



ART.

325
325/A
325/B
325/C

mm

1500
2000
2500
3000

316

~~€ 31,50~~ - € 19,00



GANCIO CON ATTACCO
A FORCELLA

300 - 1.500 mm

~~€ 94,50~~ - € 56,00

302 - 2.500 mm

~~€ 140,00~~ - € 83,00

301 - 2.000 mm

~~€ 116,00~~ - € 69,00

303 - 3.000 mm

~~€ 160,00~~ - € 95,00

CATENA CON 1 GANCIO



ART.

300
301
302
303

mm

1500
2000
2500
3000

318

~~€ 63,00~~ - € 38,00



DOPPIO GANCIO PER
AGGANCIAMENTO
E ASSEMBLAGGIO CATENE

304 - 1.500 mm

~~€ 112,00~~ - € 67,00

306 - 2.500 mm

~~€ 160,00~~ - € 95,00

305 - 2.000 mm

~~€ 140,00~~ - € 83,00

307 - 3.000 mm

~~€ 181,00~~ - € 107,00

CATENA CON 2 GANCI



ART.

304
305
306
307

mm

1500
2000
2500
3000

323

~~€ 66,50~~ - € 40,00



ACCORCIATORE
E CONGIUNTORE DI CATENA

RAPID T10

Gli apparecchi curvatubi RAPID T10 a piastra superiore scorrevole e con piastra inferiore a lettura costante, curvano a freddo senza riempimento tubi gas e acqua, senza saldatura, UNI EN10255 (BS1387 - UNI3824).



RAPID T10 MINI

~~€ 823,00~~ - € 485,00

RAPID T10 A

~~€ 998,00~~ - € 589,00

RAPID T10 B

~~€ 1.064,00~~ - € 629,00

RAPID T10 C

~~€ 1.571,00~~ - € 935,00

RAPID T10 D

~~€ 2.511,00~~ - € 1.495,00

| ART. | MATRICI CONTENUTE | | | | | | | | | |
|------|-------------------|------|------|----|--------|--------|----|--------|----|--|
| MINI | 3/8" | 1/2" | 3/4" | 1" | | | | | | |
| A | 3/8" | 1/2" | 3/4" | 1" | 1 1/4" | | | | | |
| B | 3/8" | 1/2" | 3/4" | 1" | 1 1/4" | 1 1/2" | | | | |
| C | 3/8" | 1/2" | 3/4" | 1" | 1 1/4" | 1 1/2" | 2" | | | |
| D | 3/8" | 1/2" | 3/4" | 1" | 1 1/4" | 1 1/2" | 2" | 2 1/2" | 3" | |

TREPIEDE



TP/1

~~€ 195,00~~ - € 115,00

PER ART. MINI • A • B • C • D



24020 VILLA DI SERIO (BG) ITALY

Via Divisione Tridentina, 23

T. 035 423 44 11 • F. 035 423 44 41 • 035 423 44 42

www.omcn.it • info@omcn.it

EXPORT

T. +39 035 423 44 16 • F. +39 035 423 44 49

www.omcn.com • info@omcn.com